

8

7

6

5

4

3

2

1

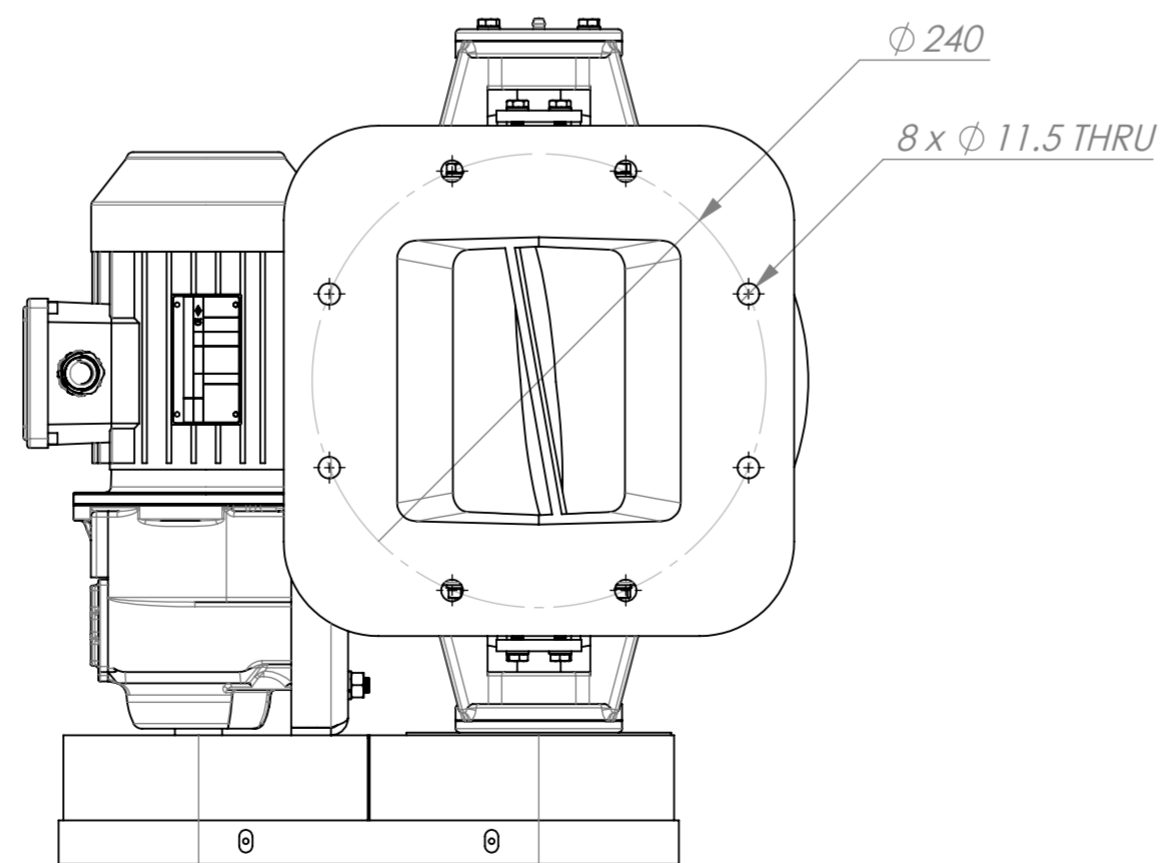
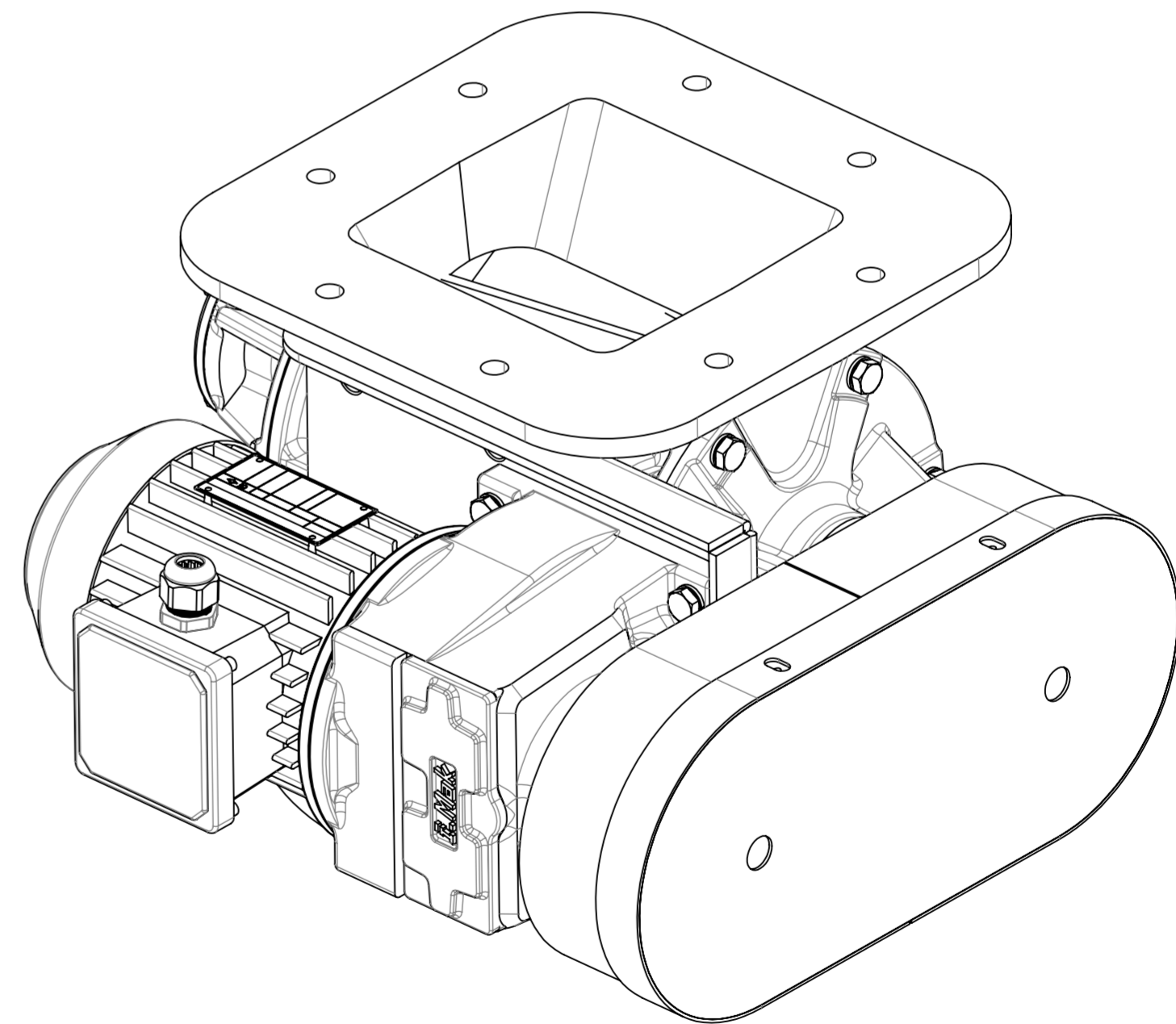
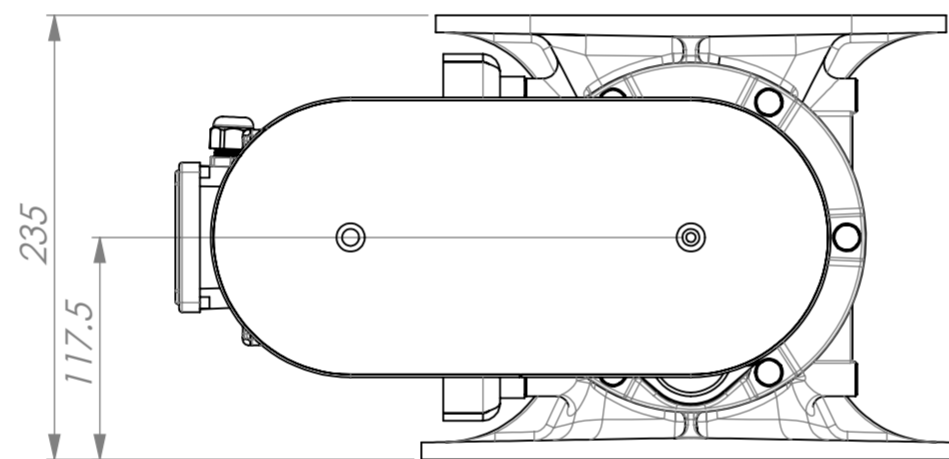
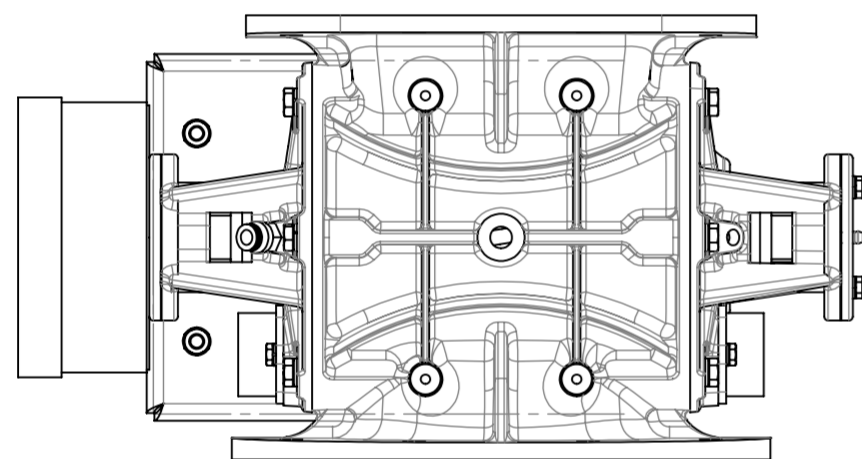
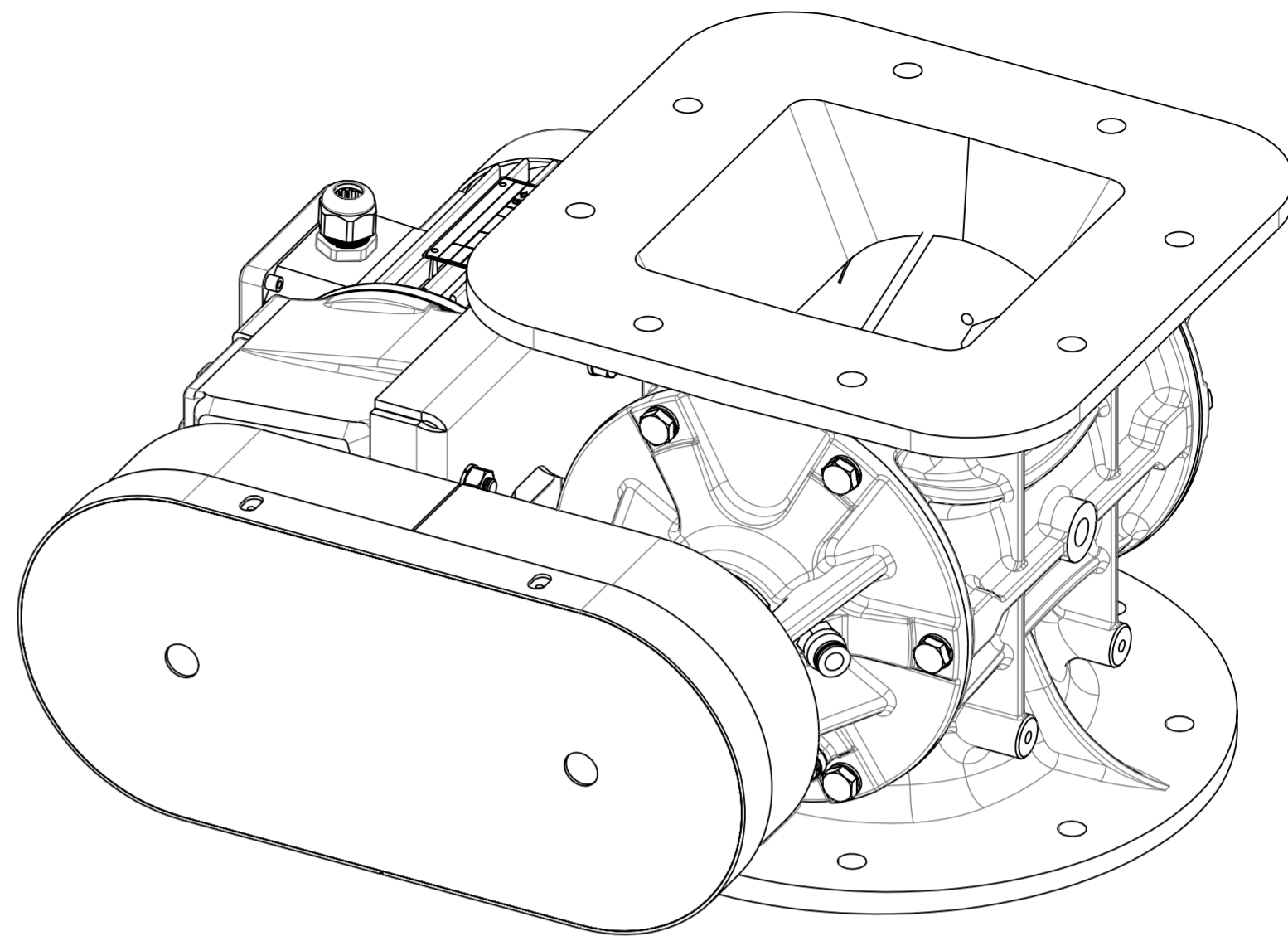
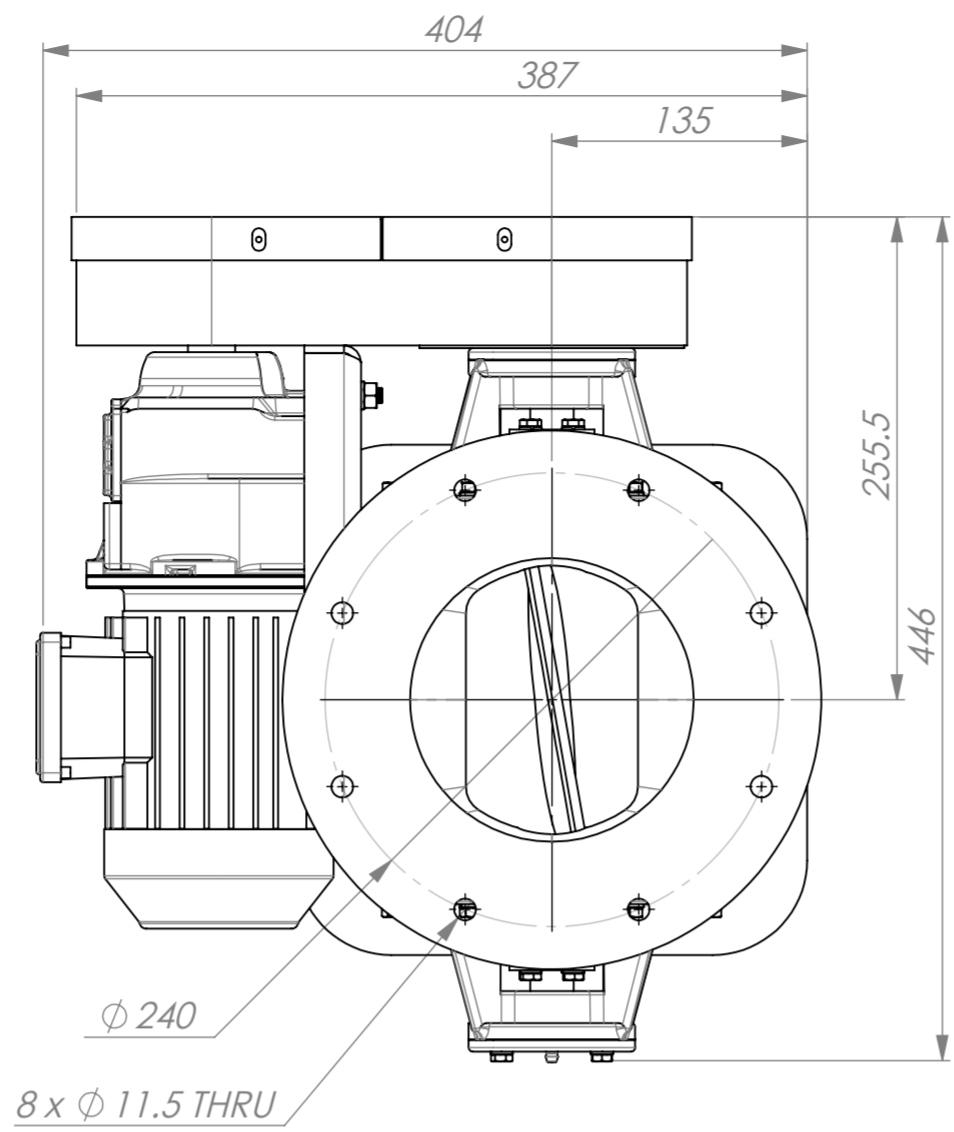

UNLESS OTHERWISE SPECIFIED			LAST DATUM LRT USED			CUSTOMER: Padideh Kimia Co.		
1. MARKING PER ISO 2842			HEAT TREAT:			DESIGN: ESGM Co.		
2. BREAK ALL SHARP EDGES 0.1 X 45° OR 0.1R			FINISH SPEC.			MET PRE:		
3. DIMENSIONAL LIMITS APPLY AFTER PLATING			UNLESS OTHERWISE SPECIFIED DIMENSION ARE IN MILLIMETER			DESIGN APP:		
APPLICABLE DOCUMENTS			GENERAL STANDARD AS PER			GROUP PRE:		
ABBREVIATIONS PER ISO-STD			MACHINING ISO 2768-1 mK			ENGR. APP:		
HEAT TREATMENT			LASER CUTTING ISO 2768-1 cK			DRAWN:		
FERROUS MATERIALS AS PER ISO 4885			PLASMA CUTTING ISO 2768-1 vK			CHECKED:		
			GEOMETRICAL TOLERANCE ISO 2768-2			APPROVED:		
			CASTING ISO 8052-CT11			SCALE: 1:4		
			SURFACE ROUGHNESS ISO 1302			FILE CODE:		
			GALVANIZED COATING ISO 1461			REFERENCE:		
			Corrosion Protection ISO 8501-1:2004			Rev. 0		

DASH NO.	NEXT ASSY.	USED ON APPLICATION



PART NAME: **8 - Chassis 2 Overall Dimension**

PART NO.

SIZE A2 REFERENCE: SHEET 1 OF 1

8

7

6

5

4

3

2

1