

8

7

6

5

4

3

2

1

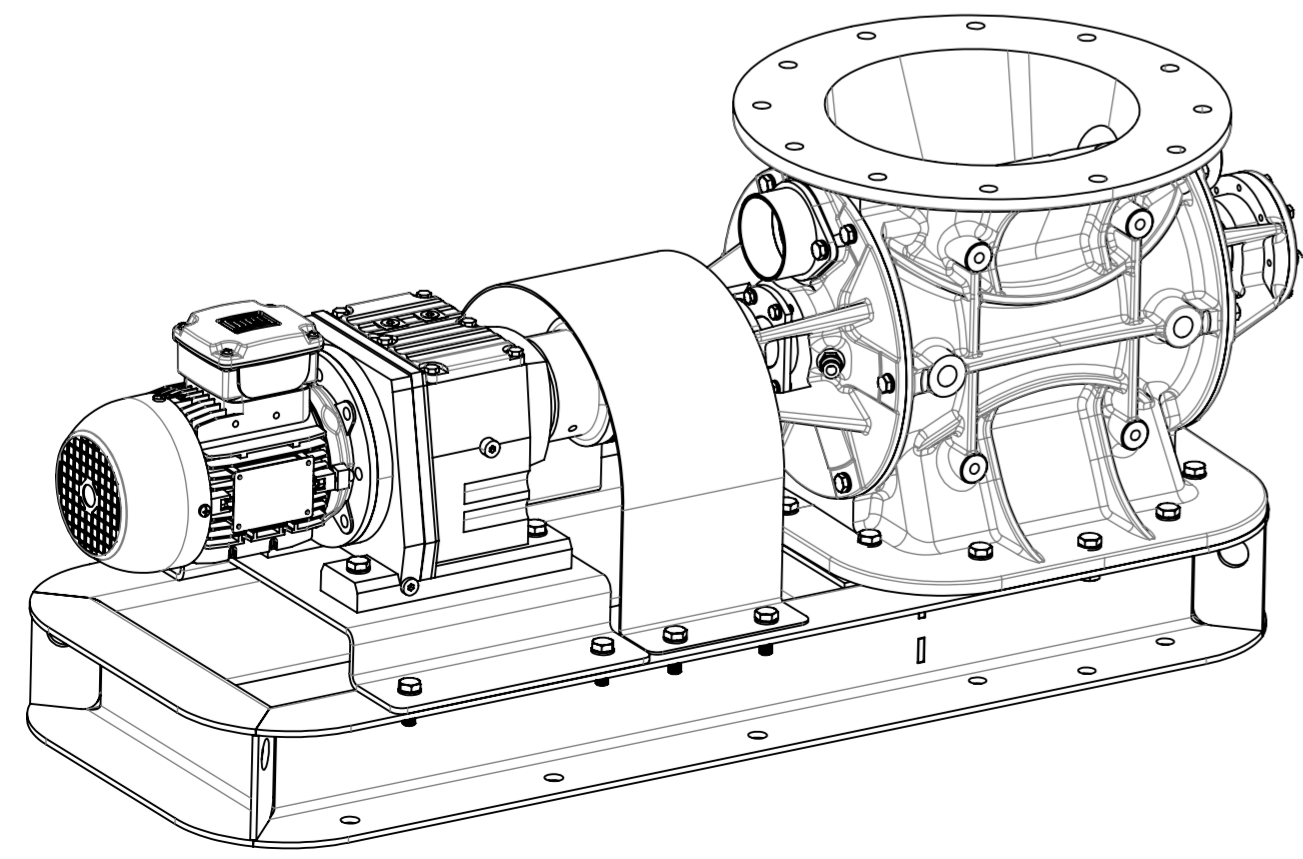
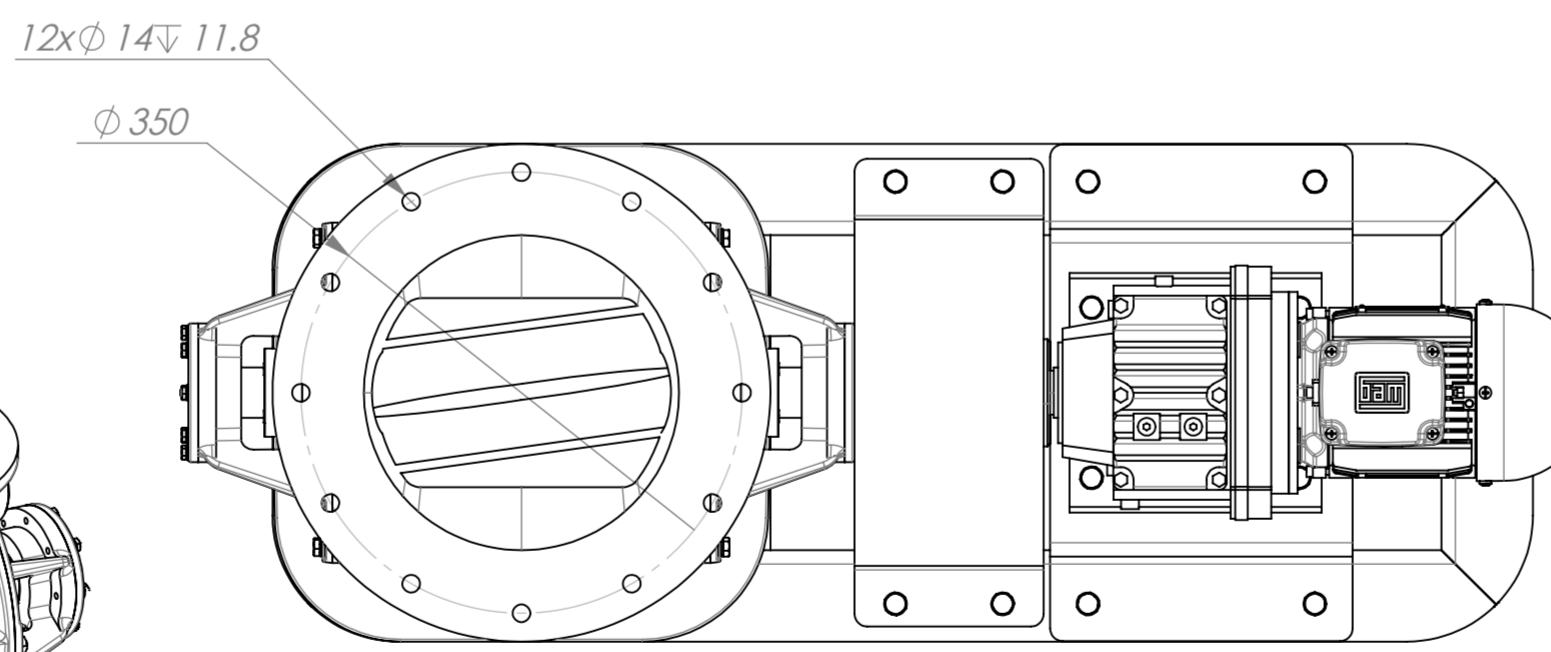
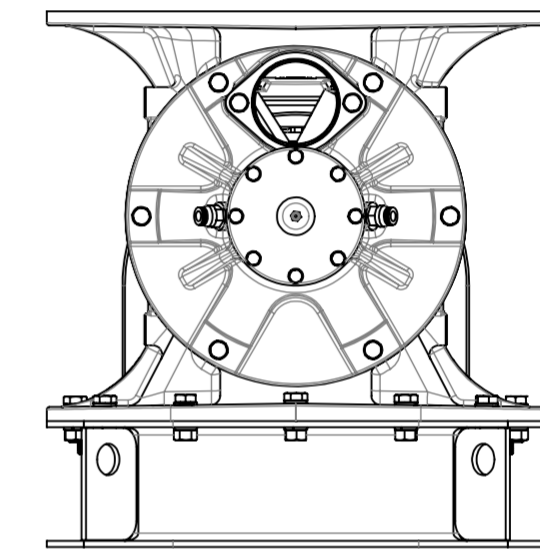
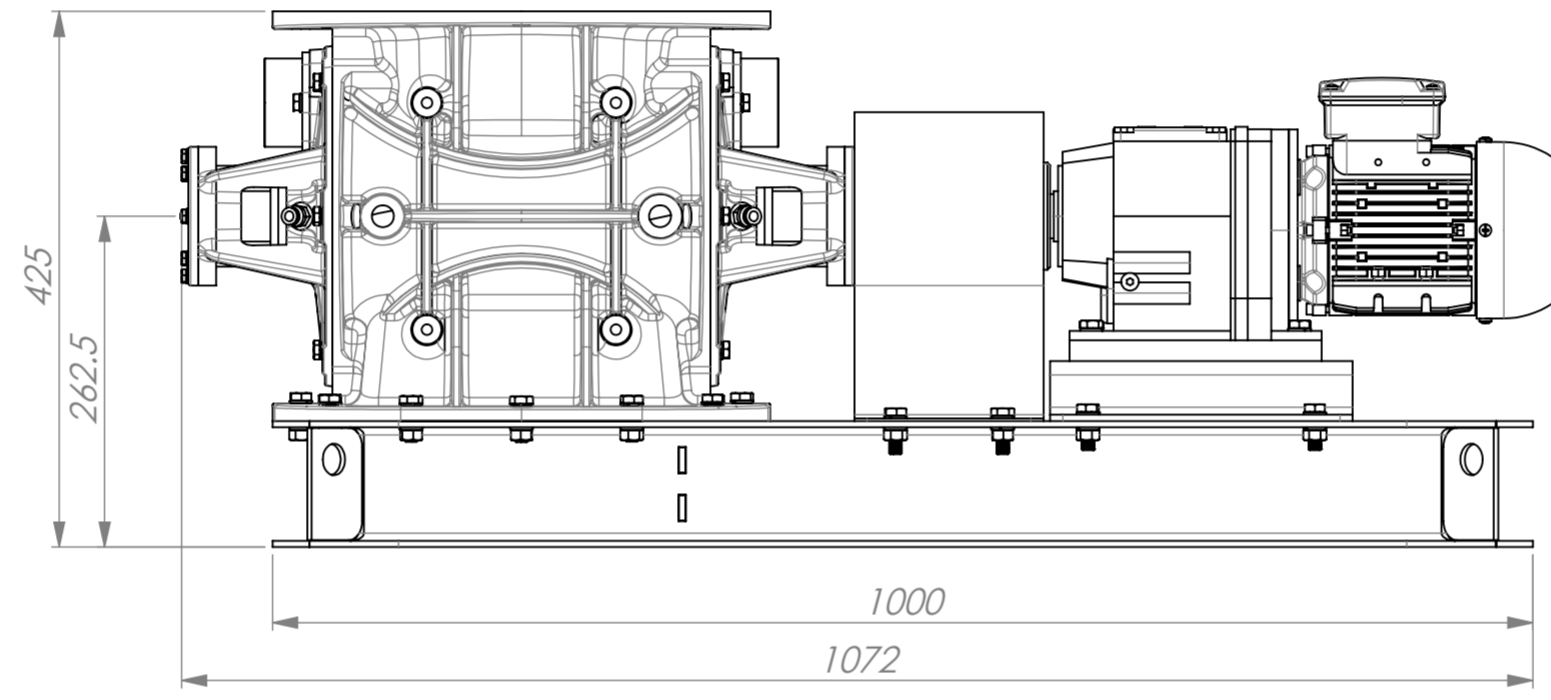
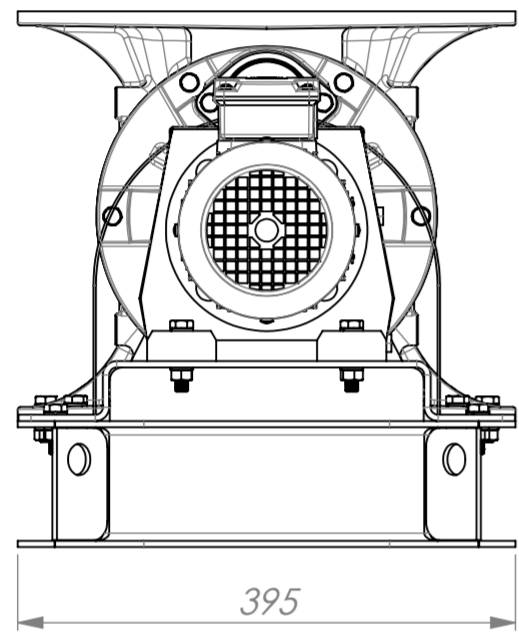
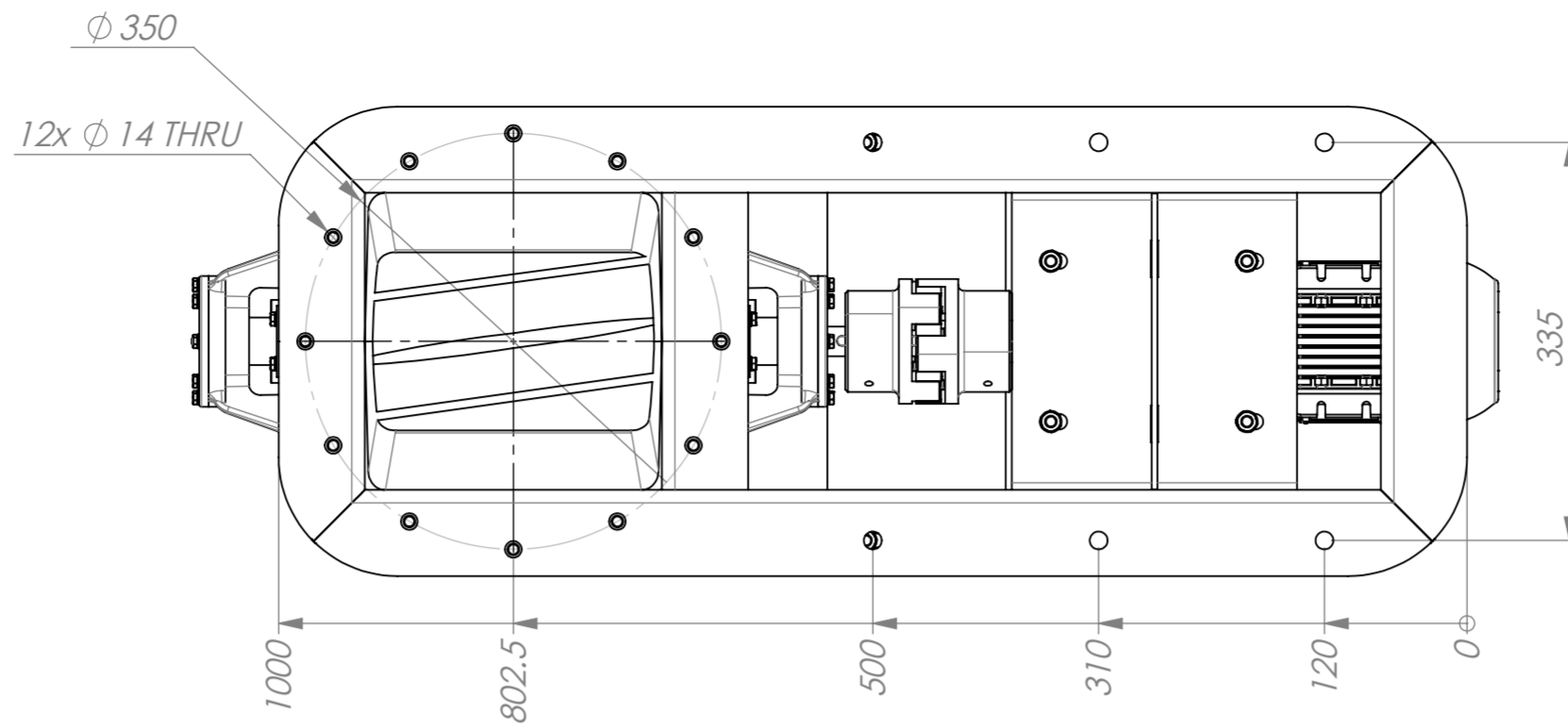

8

7

6

5

4

3

2

1

DASH NO.	NEXT ASSY.	USED ON APPLICATION

UNLESS OTHERWISE SPECIFIED
1. MARKING PER ISO 2842
2. BREAK ALL SHARP EDGES 0.1 X 45° OR 0.1R
3. DIMENSIONAL LIMITS APPLY AFTER PLATING

HEAT TREAT:
FINISH SPEC.
UNLESS OTHERWISE SPECIFIED DIMENSION ARE IN MILLIMETER

GENERAL STANDARD AS PER
MACHINING ISO 2768-1 mK
LASER CUTTING ISO 2768-1 cK
PLASMA CUTTING ISO 2768-1 vK
GEOMETRICAL TOLERANCE ISO 2768-2
CASTING ISO 8862-C111
SURFACE ROUGHNESS ISO 1302
FERROUS MATERIALS AS PER ISO 4885
GALVANIZED COATING ISO 1461
Corrosion Protection ISO 8501-1:2004

CUSTOMER:
DESIGN:
MET PRE:
DESIGN APP:
GROUP PRE:
ENGR. APP:
DRAWN:
CHECKED:
APPROVED:

AMMAD

PART NAME:
10" - Chassis 1 Overall Dimension

PART NO. _____

SIZE **A2** REFERENCE: _____ Rev. _____

SCALE: 1:6 FILE CODE: _____ SHEET 1 OF 1