

8

7

6

5

4

3

2

1

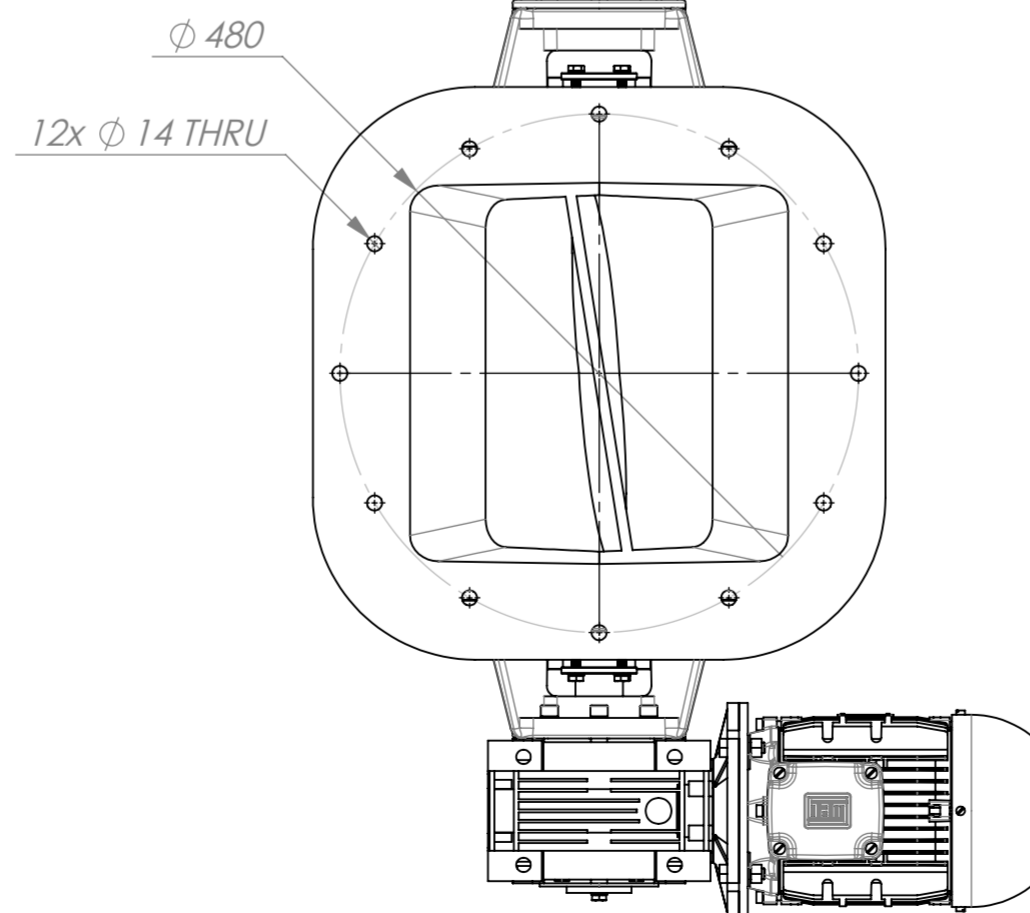
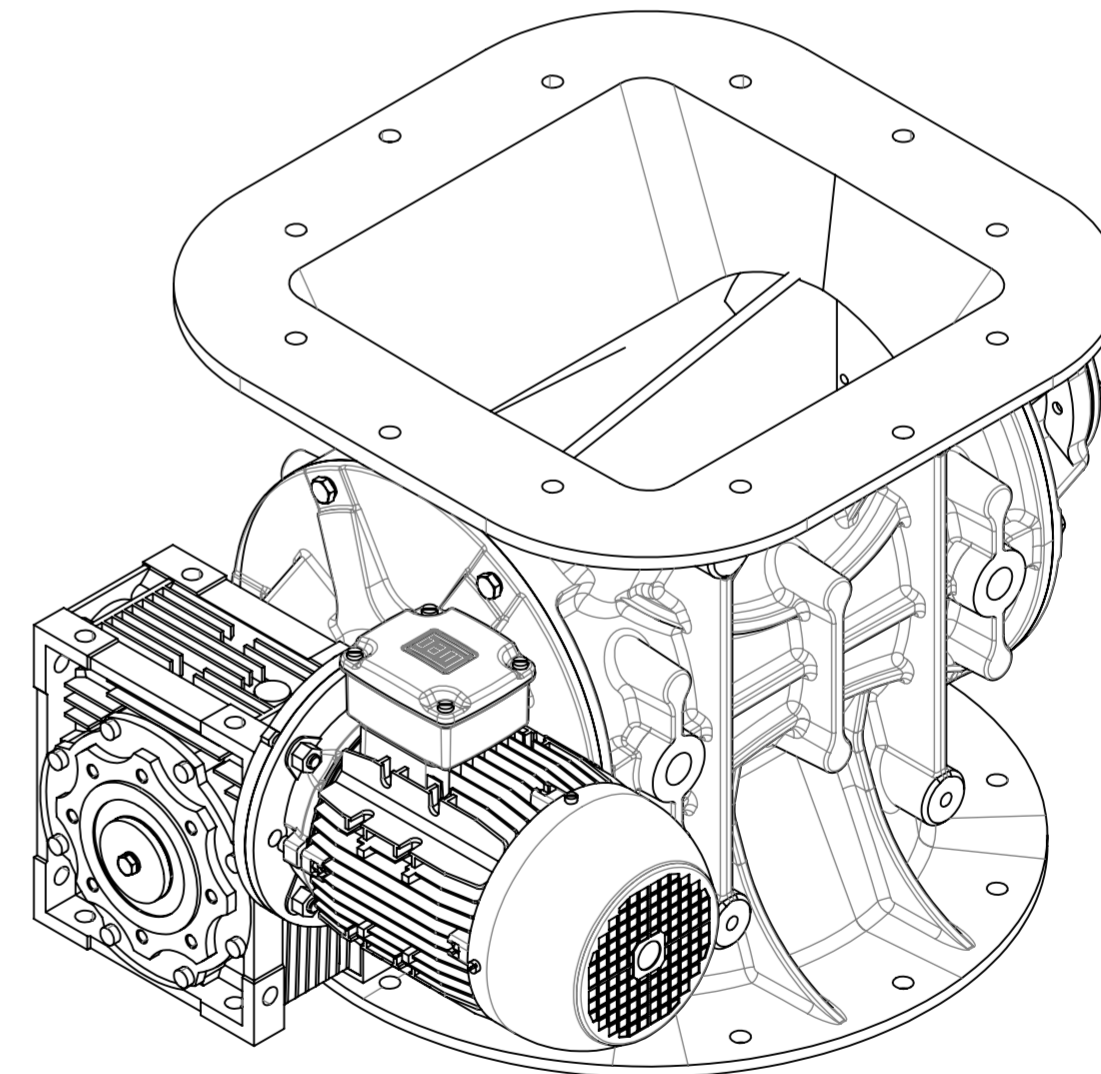
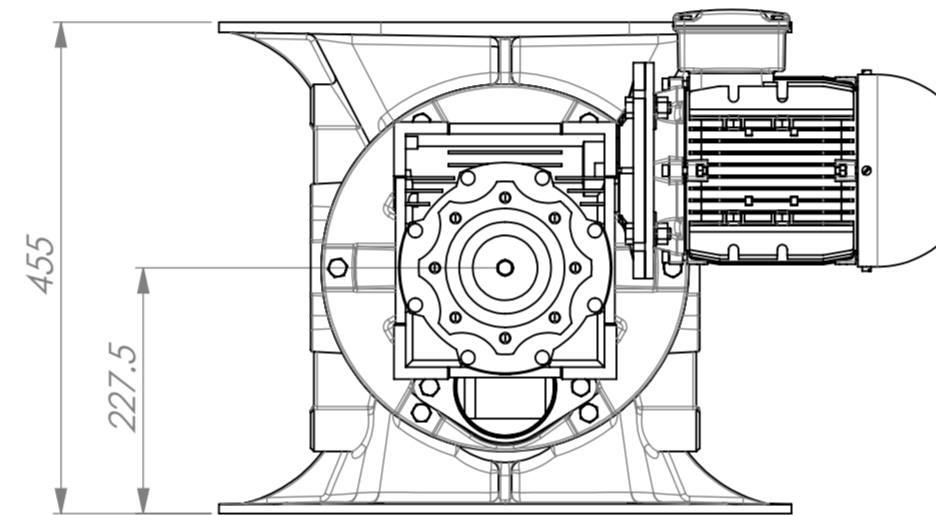
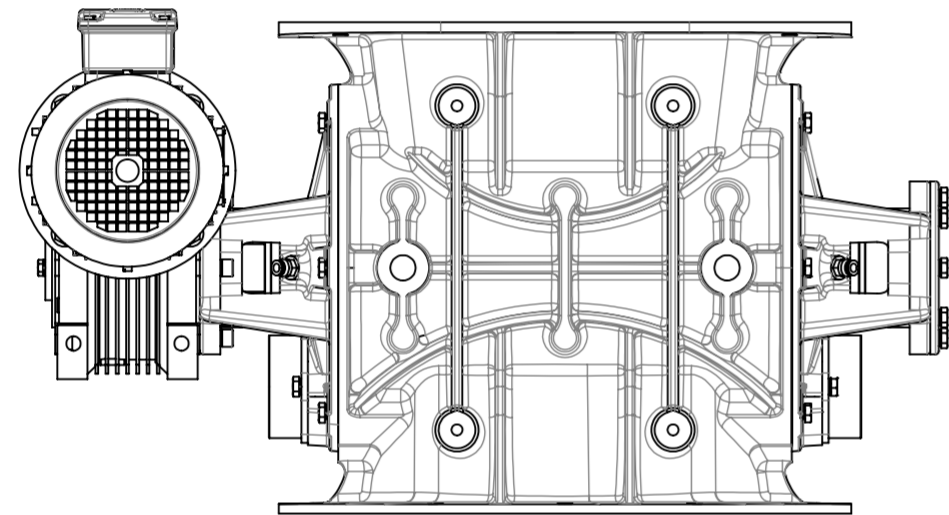
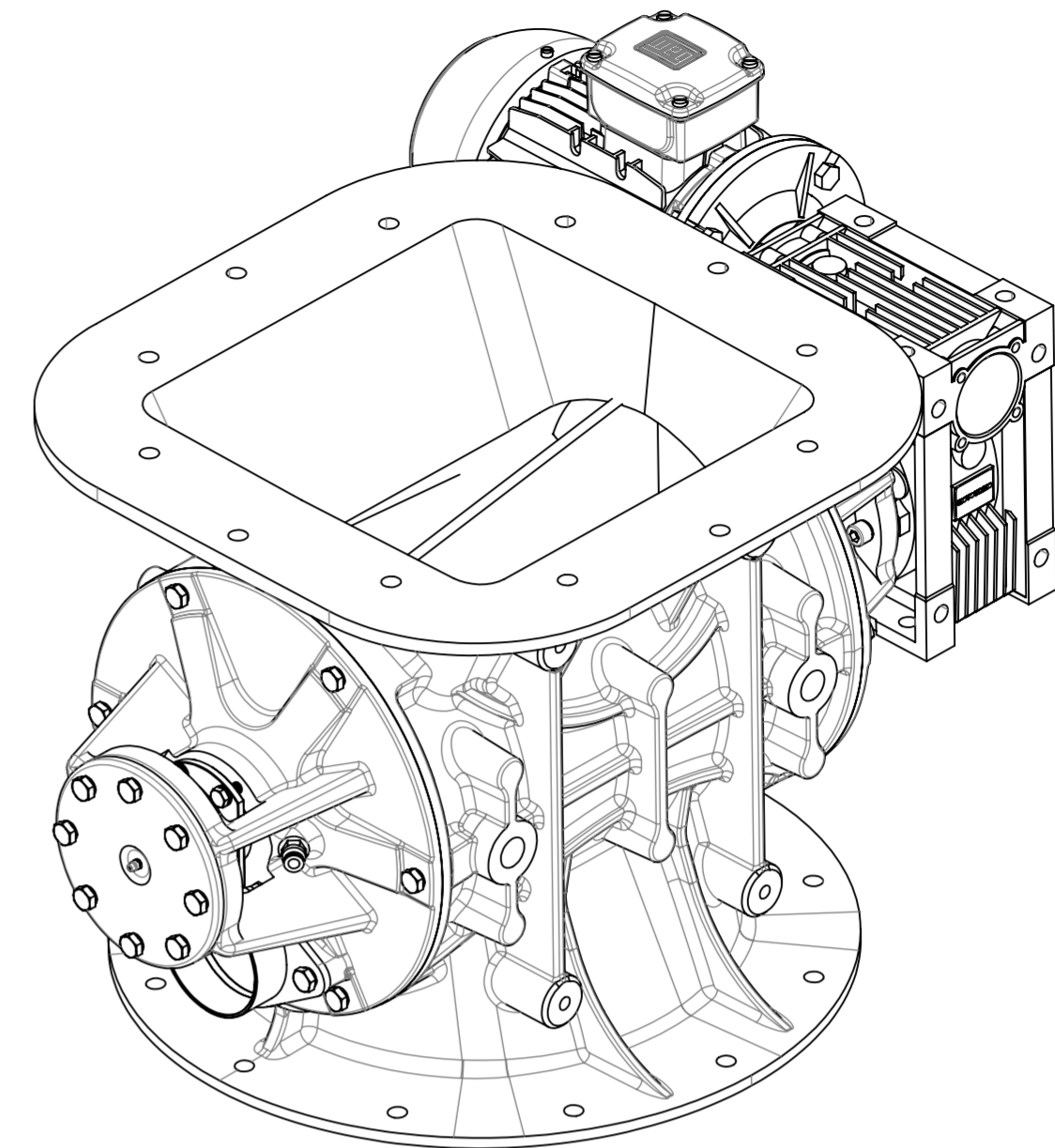
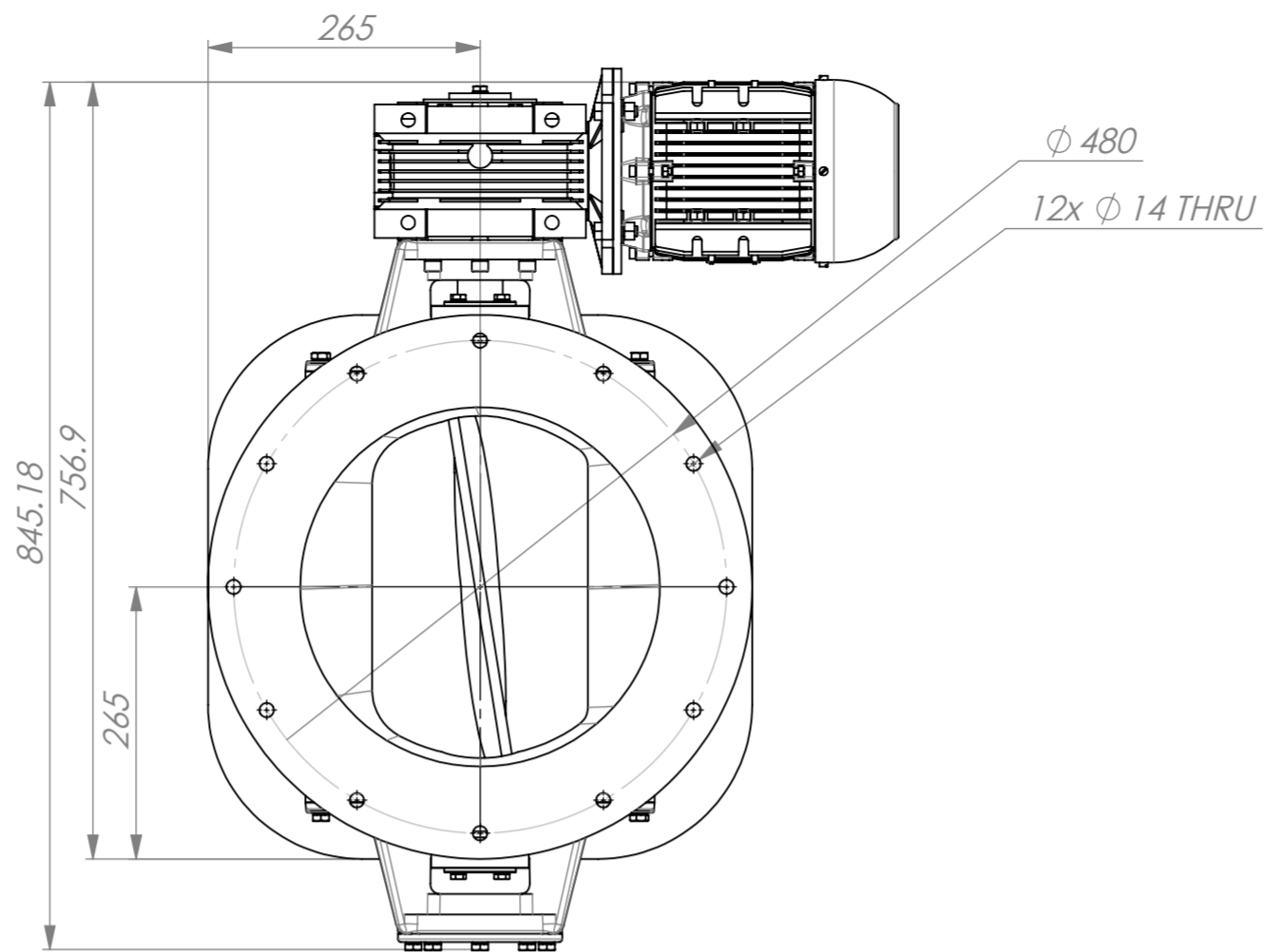

DASH NO.	NEXT ASSY.	USED ON APPLICATION

UNLESS OTHERWISE SPECIFIED
 1. MARKING PER ISO 2842
 2. BREAK ALL SHARP EDGES 0.1 X 45° OR 0.1R
 3. DIMENSIONAL LIMITS APPLY AFTER PLATING

LAST DATUM LRT USED
 HEAT TREAT:
 FINISH SPEC.
 UNLESS OTHERWISE SPECIFIED DIMENSION ARE IN MILLIMETER

CUSTOMER: Padideh Kimia Co.
 DESIGN: ESGM Co.
 MET PRE:
 APP: DESIGN
 GROUP PRE:
 ENGR. APP: DESIGN
 DRAWN:
 CHECKED:
 APPROVED:

PART NAME: **14" Advance Rotary Valve**
 PART NO.:
 SIZE: A2
 REFERENCE:
 SCALE: 1:7
 FILE CODE:
 SHEET 1 OF 1



8

7

6

5

4

3

2

1

D

C

B

A