

6

5

4

3

2

1

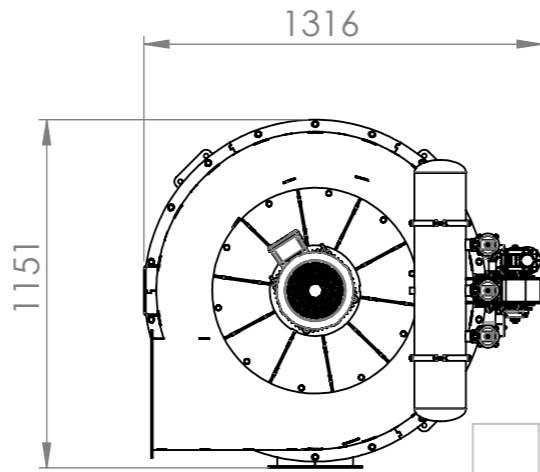
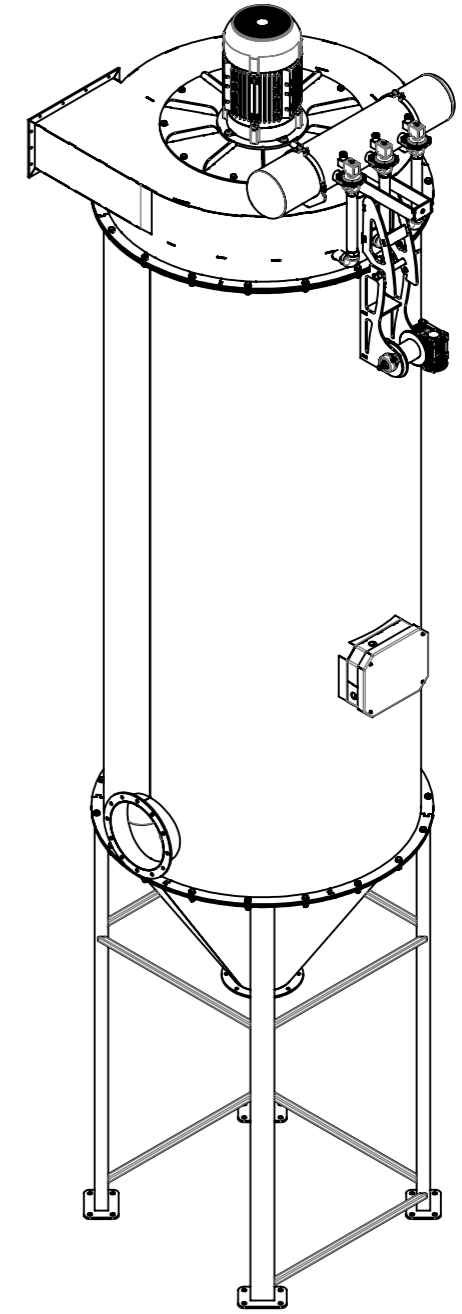
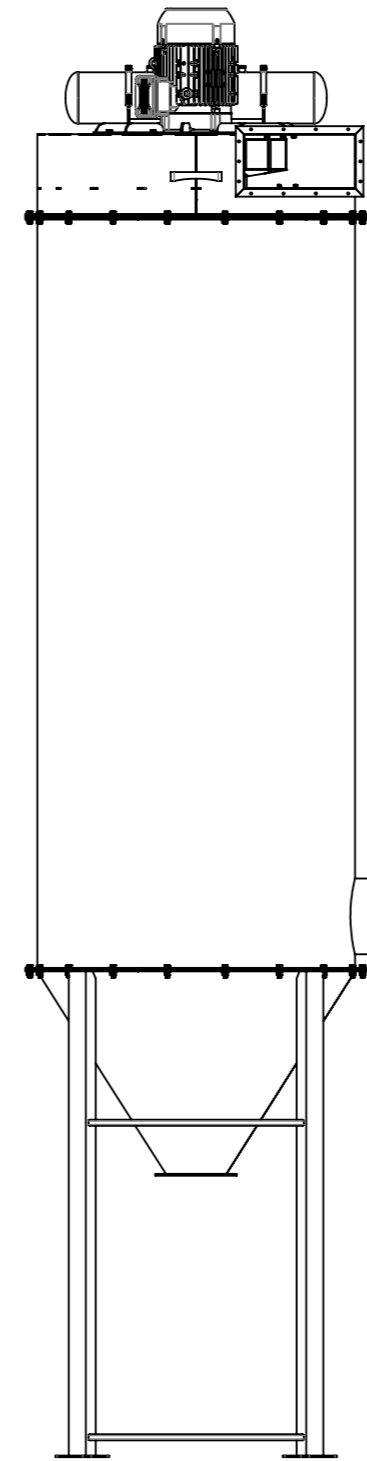
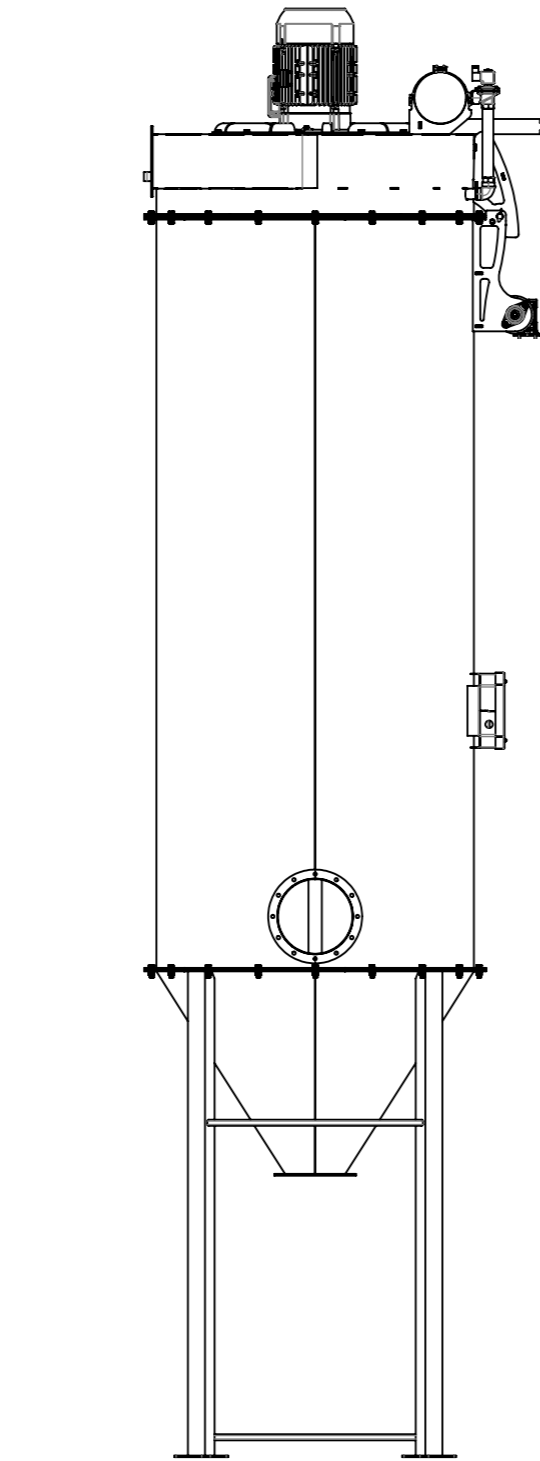
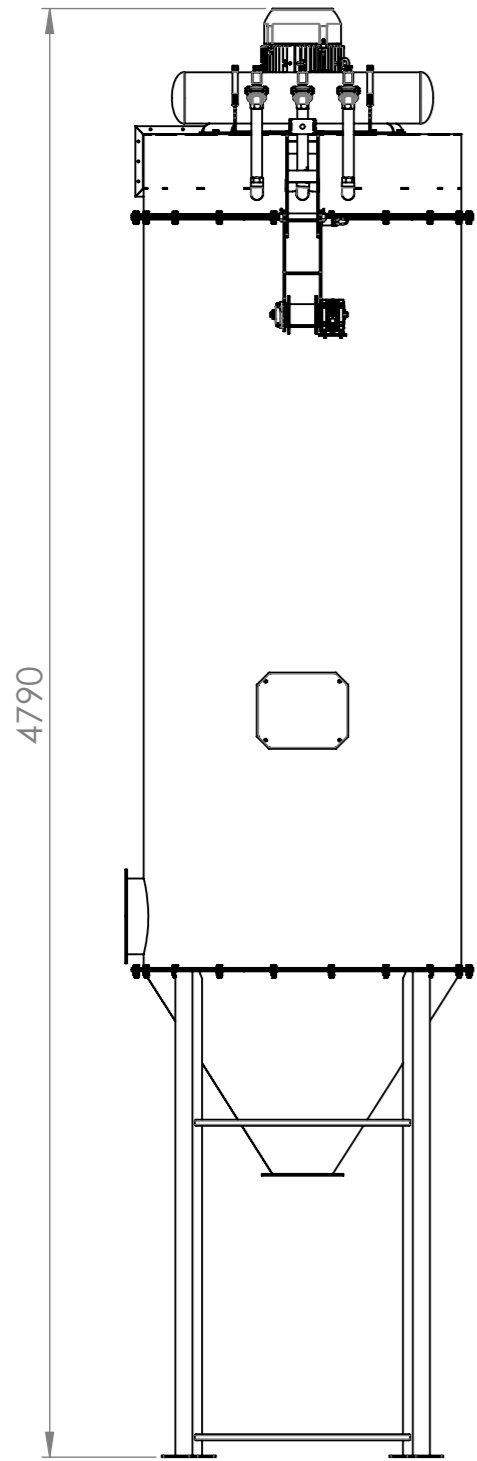

DASH NO.	NEXT ASSY.	USED ON
	APPLICATION	

UNLESS OTHERWISE SPECIFIED	LAST DATUM LRT USED	CUSTOMER: Padideh Kimia Co.
1. MARKING PER ISO 2862	HEAT TREAT:	DESIGN: ESGM Co.
2. BREAK ALL SHARP EDGES 0.1 X 45° OR 0.1R	FINISH SPEC.	MET PRE:
3. DIMENSIONAL LIMITS APPLY AFTER PLATING	UNLESS OTHERWISE SPECIFIED DIMENSION ARE IN MILLIMETER	DESIGN APP:
APPLICABLE DOCUMENTS	GENERAL STANDARD AS PER	GROUP PRE:
ABBREVIATIONS PER ISO-STD	MACHINING ISO 2768-1 mk	ENGR. APP:
HEAT TREATMENT	LASER CUTTING ISO 2768-1 ck	DRAWN:
FERROUS MATERIALS AS PER ISO 4885	PLASMA CUTTING ISO 2768-1 vk	CHECKED:
	GEOMETRICAL TOLERANCE ISO 2768-2	APPROVED:
	CASTING ISO 8062-CT11	
	SURFACE ROUGHNESS ISO 1302	
	GALVANIZED COATING ISO 1461	
	Corrosion Protection ISO 8501-12944	

PART NAME:	24 Bag Cement BagHouse	
PART NO.	21.CBH07.00	
SIZE	REFERENCE:	Rev.
A3	SCALE:1:25	0
FILE CODE:	SHEET 1 OF 1	



D

D

C

C

B

B

A

A

6

5

4

3

2

1