

6

5

4

3

2

1

D

D

C

C

B

B

A

A

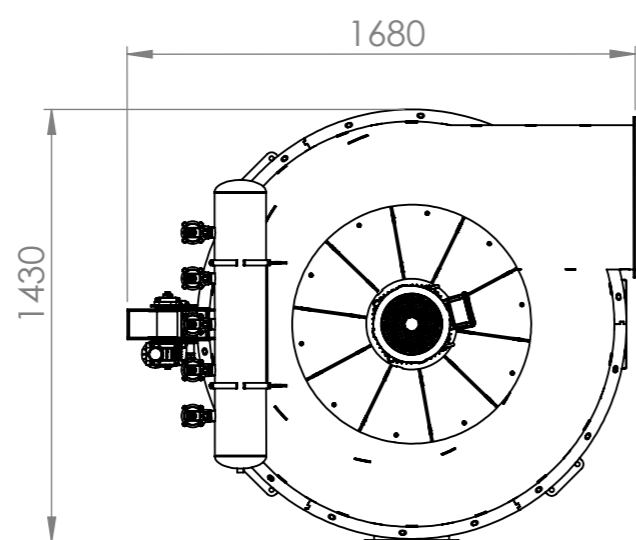
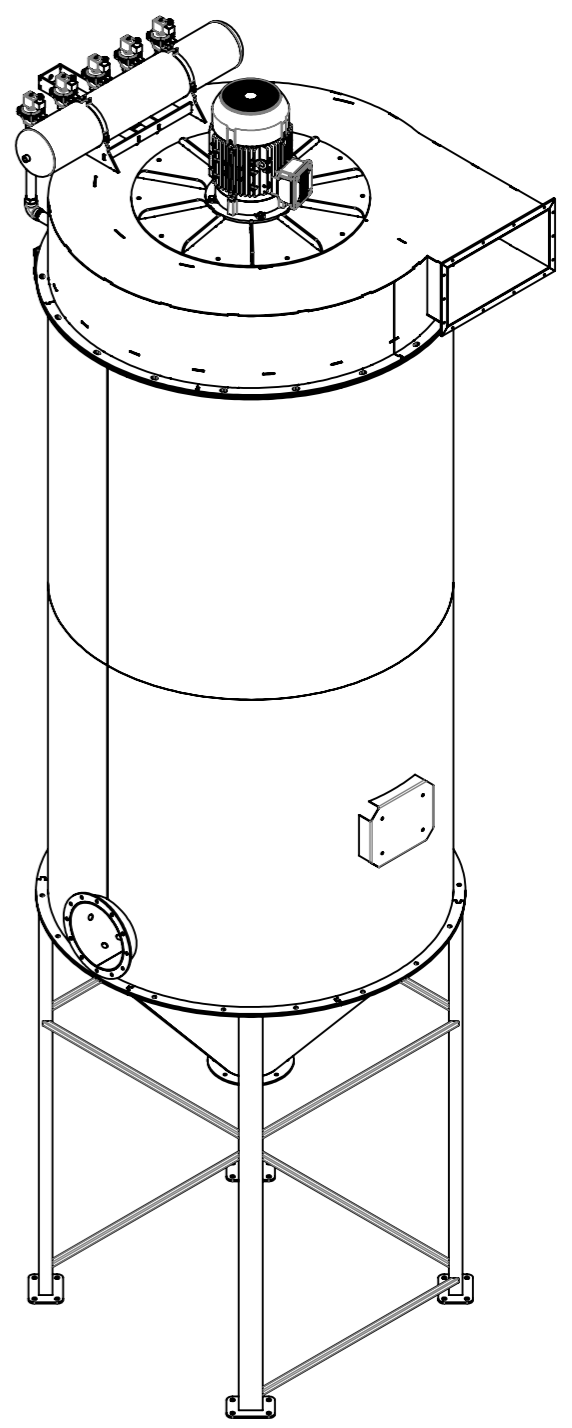
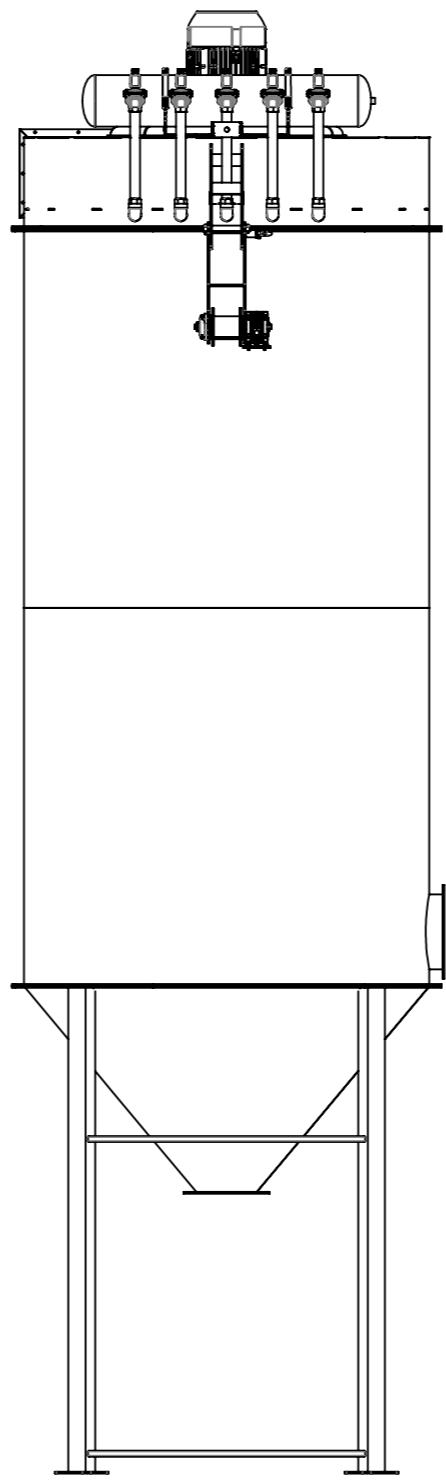
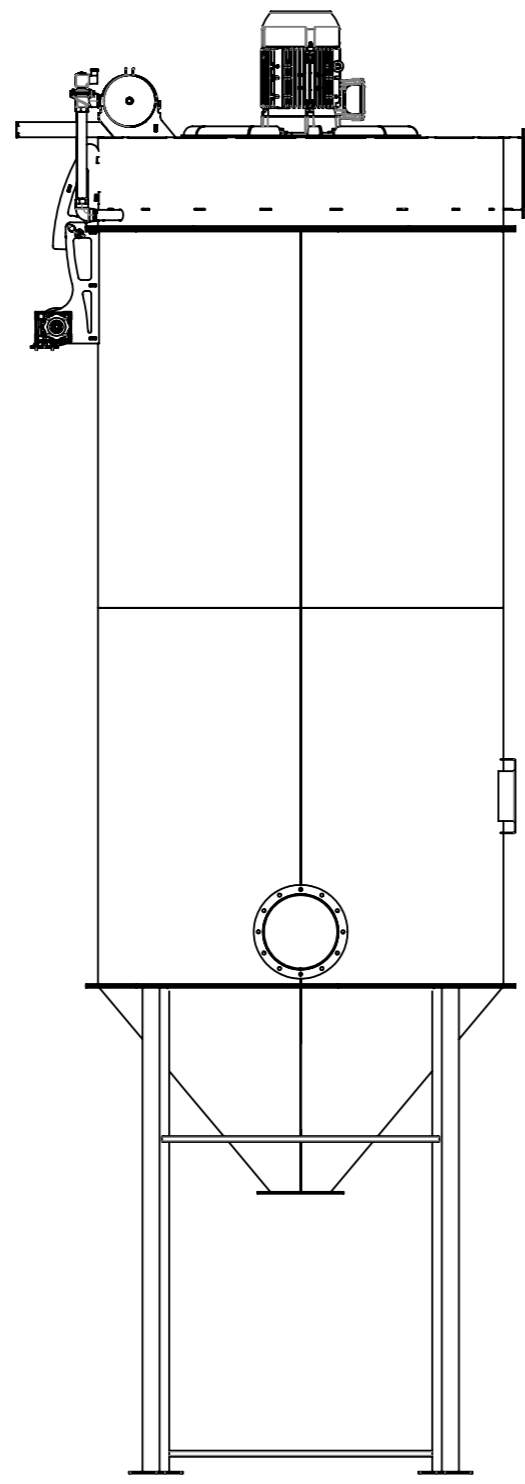
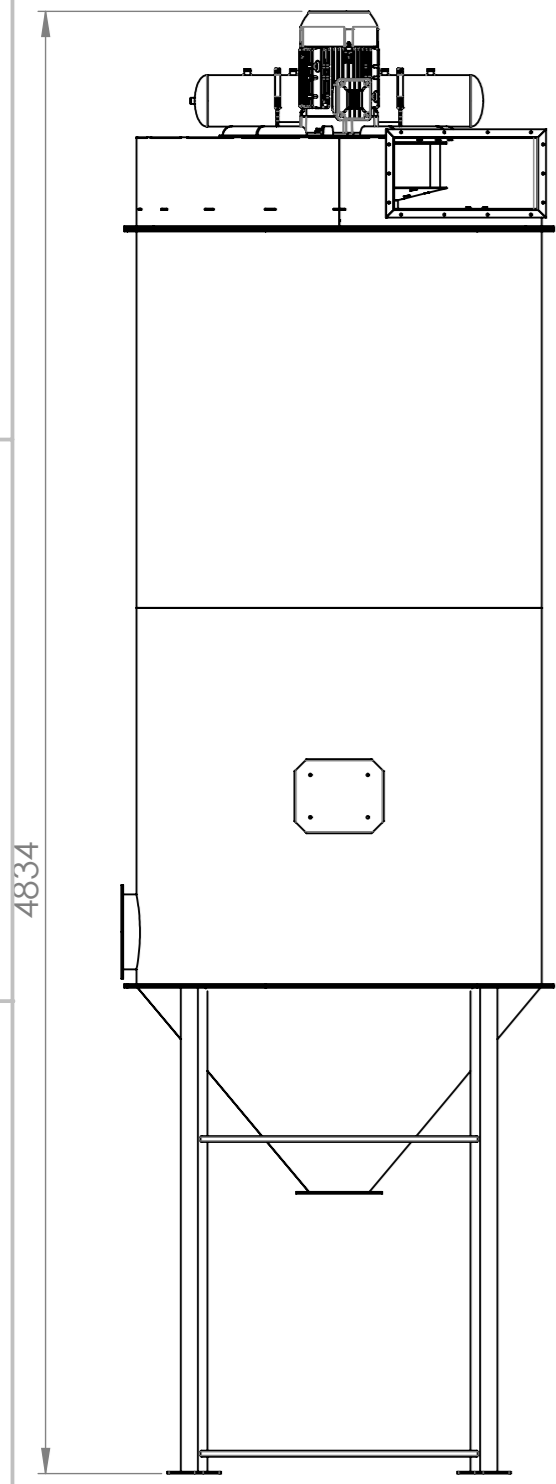

DASH NO.	NEXT ASSY.	USED ON
	APPLICATION	

UNLESS OTHERWISE SPECIFIED 1. MARKING PER ISO 2862 2. BREAK ALL SHARP EDGES 0.1 X 45° OR 0.1R 3. DIMENSIONAL LIMITS APPLY AFTER PLATING	LAST DATUM LRT USED HEAT TREAT: FINISH SPEC. UNLESS OTHERWISE SPECIFIED DIMENSION ARE IN MILLIMETER GENERAL STANDARD AS PER MACHINING ISO 2768-1 mk LASER CUTTING ISO 2768-1 ck PLASMA CUTTING ISO 2768-1 vk GEOMETRICAL TOLERANCE ISO 2768-2 CASTING ISO 8062-CT11 SURFACE ROUGHNESS ISO 1302 GALVANIZED COATING ISO 1461 Corrosion Protection ISO 8501-12944	CUSTOMER: DESIGN: MET PRE: DESIGN APP: GROUP PRE: ENGR. APP: DRAWN: CHECKED: APPROVED:
--	---	--

PART NAME:	Rev.
PART NO.	
SIZE A3	REFERENCE:
SCALE:1:25	FILE CODE:
SHEET 1 OF 1	

6

5

4

3

2

1