

8

7

6

5

4

3

2

1

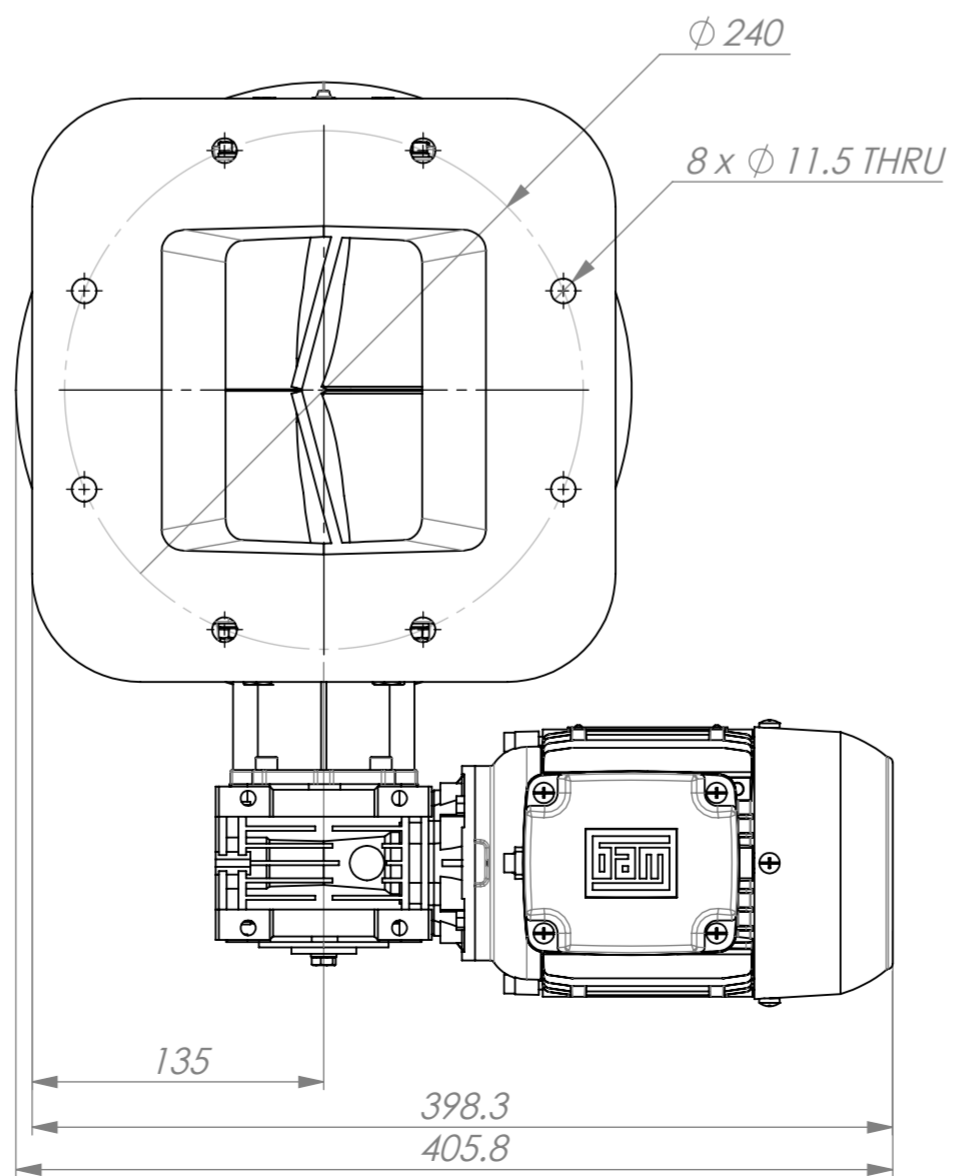
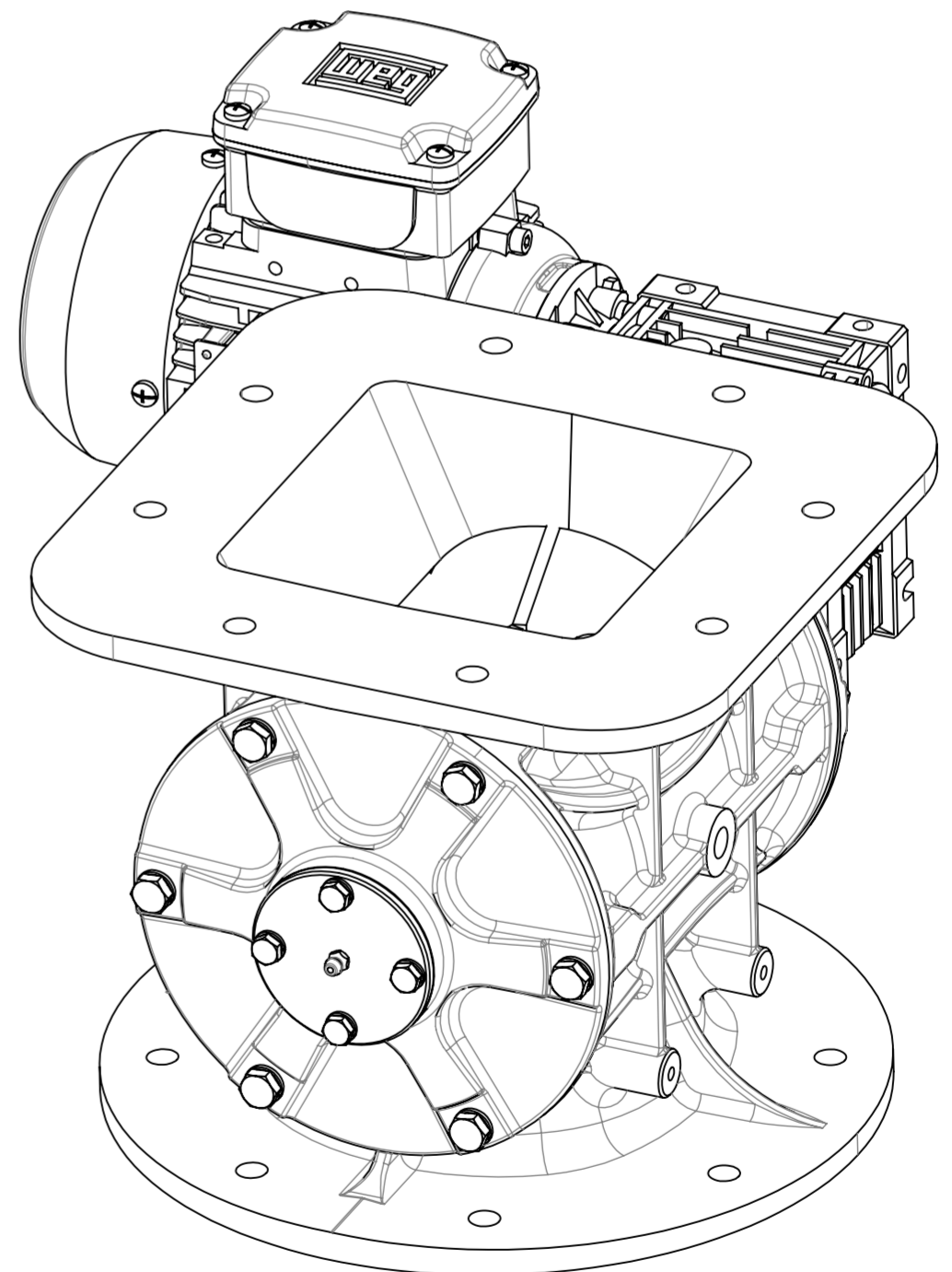
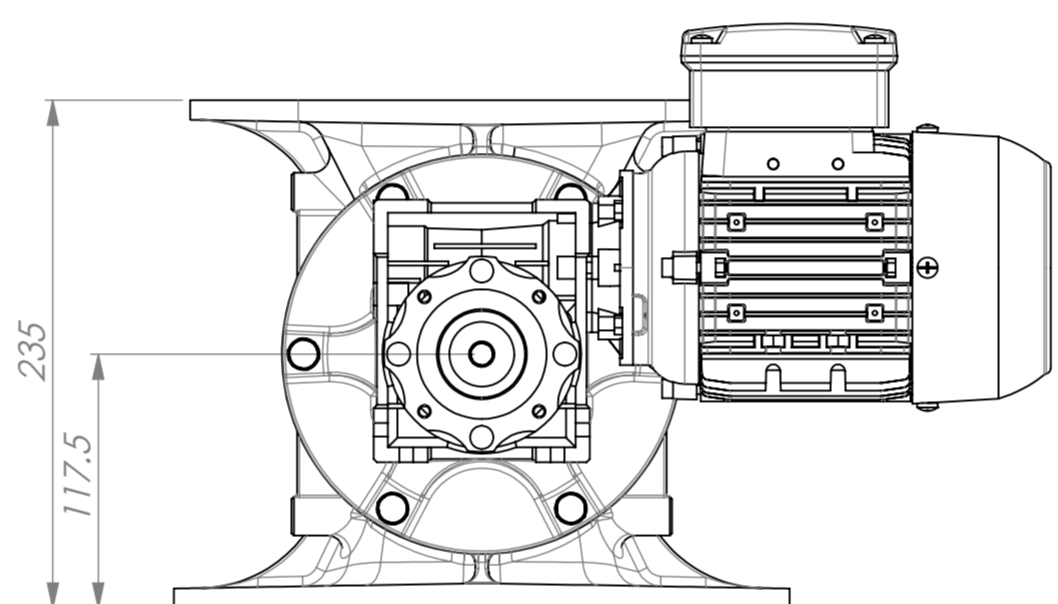
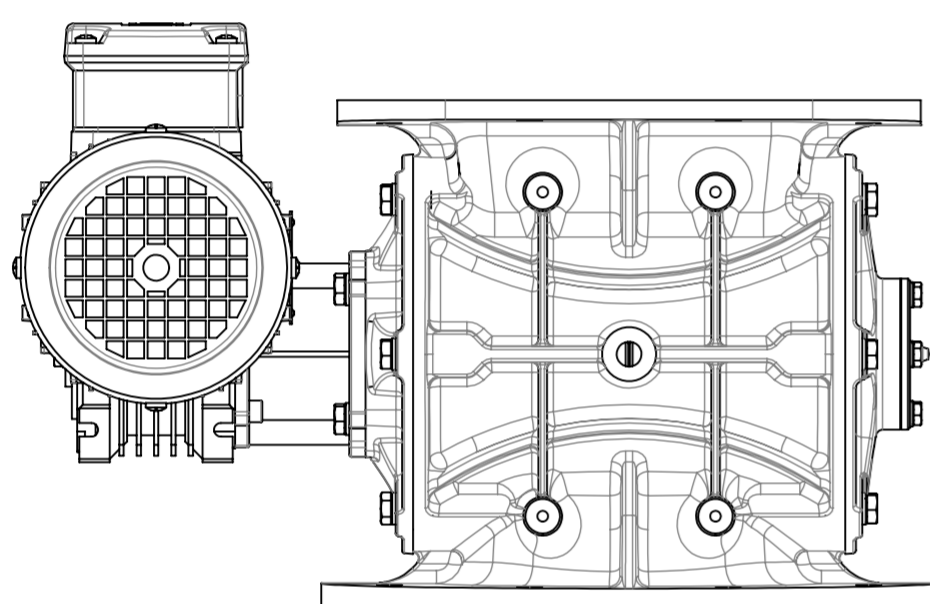
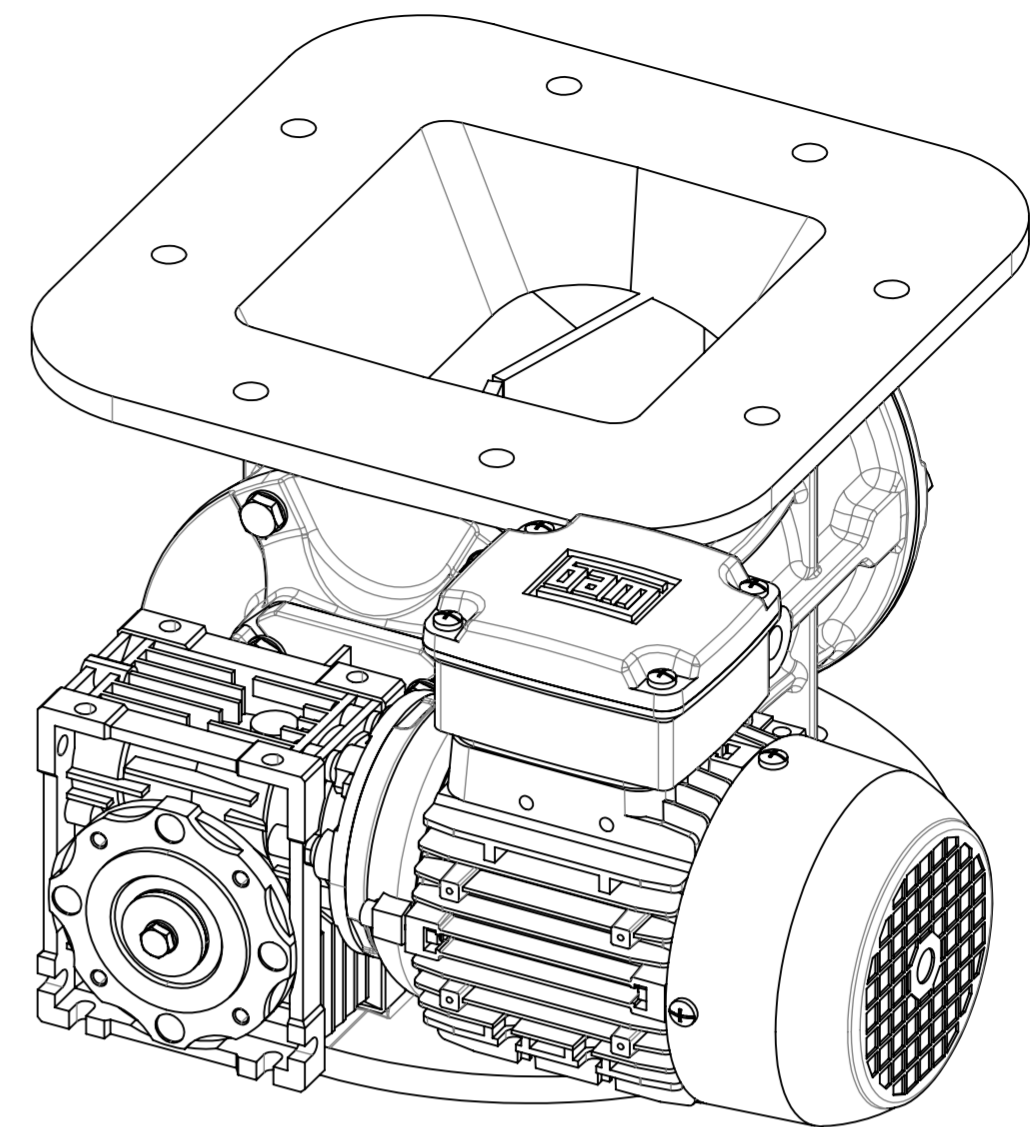
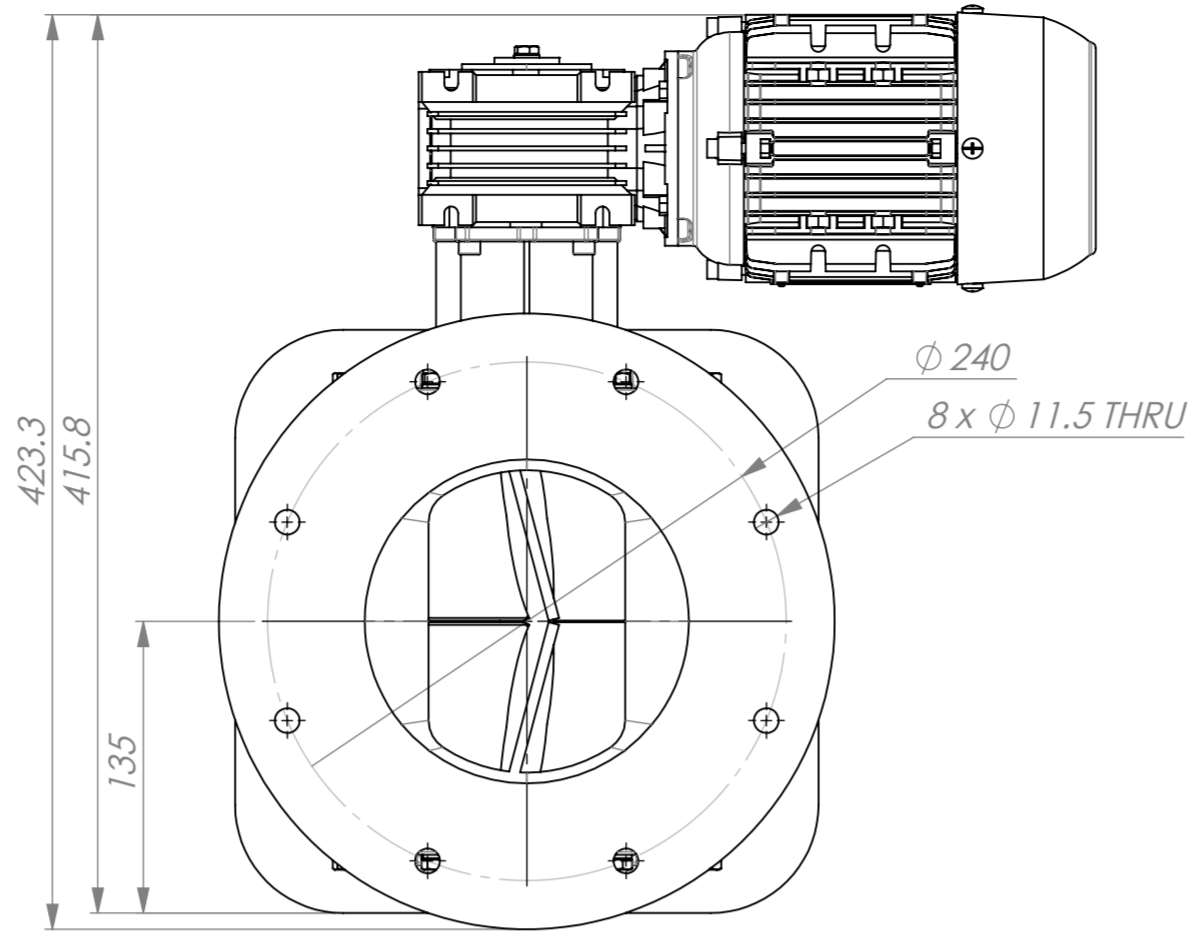

DASH NO.	NEXT ASSY.	USED ON APPLICATION

UNLESS OTHERWISE SPECIFIED 1. MARKING PER ISO 2842 2. BREAK ALL SHARP EDGES 0.1 X 45° OR 0.1R 3. DIMENSIONAL LIMITS APPLY AFTER PLATING	LAST DATUM LRT USED HEAT TREAT: FINISH SPEC. UNLESS OTHERWISE SPECIFIED DIMENSION ARE IN MILLIMETER	CUSTOMER: DESIGN: MET DESIGN PRE: APP: GROUP ENG. APP: DRAWN: CHECKED: APPROVED:
--	---	---

ESGM	
PART NAME:	6" Simple Rotary Valve
PART NO.	
SIZE A2	REFERENCE: SCALE: 1:3.5
FILE CODE:	Rev. 0
SHEET 1 OF 1	

8

7

6

5

4

3

2

1