

8 7 6 5 4 3 2 1

D

D

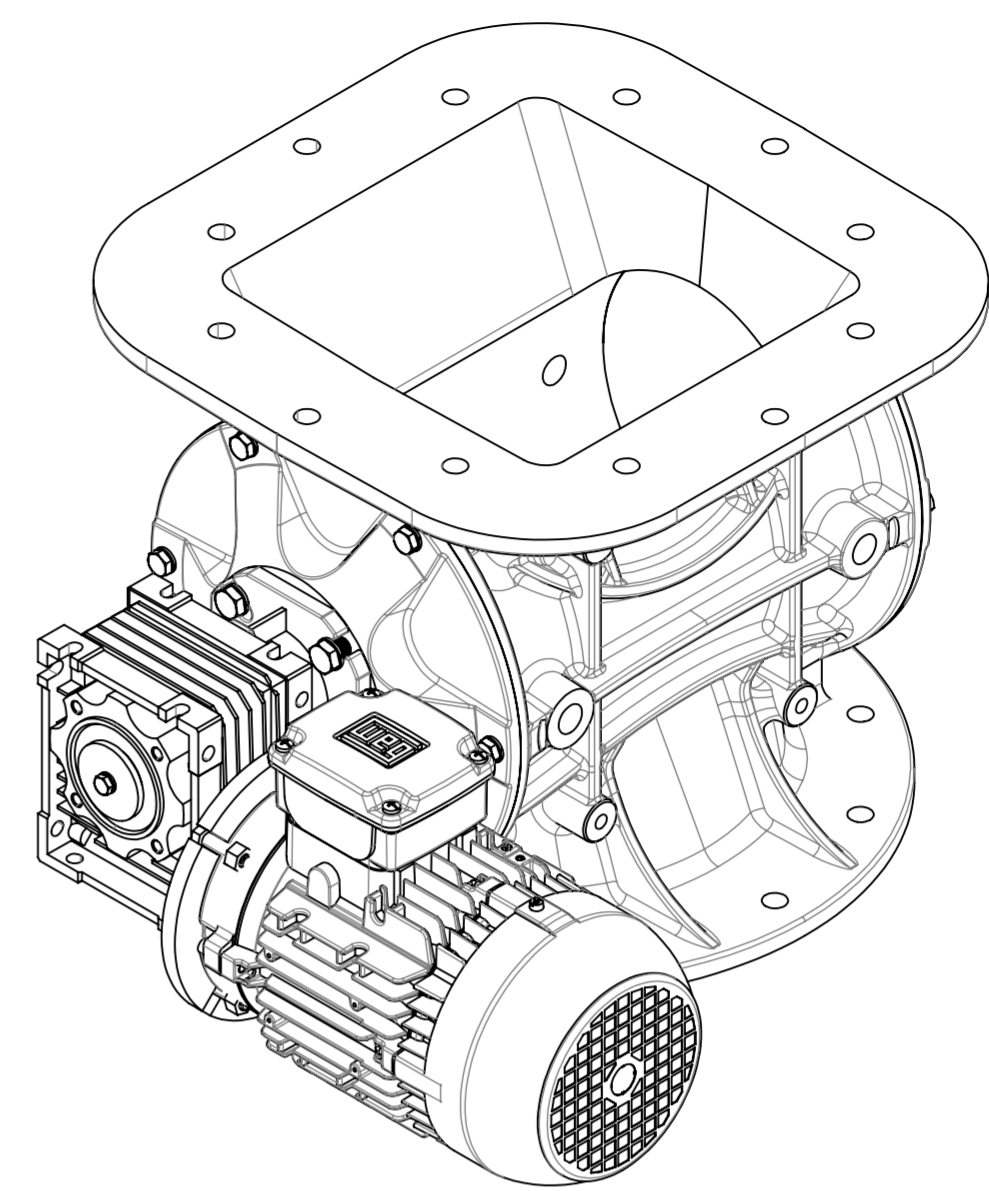
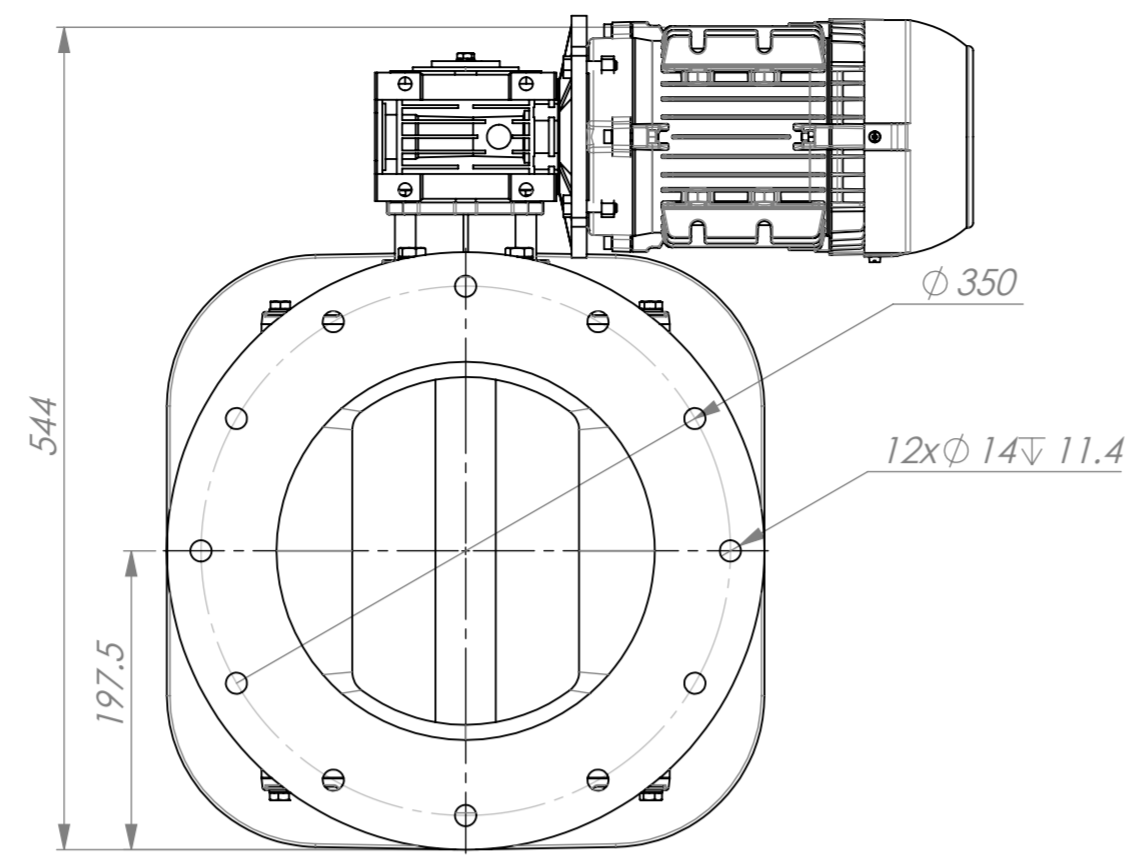

C

C

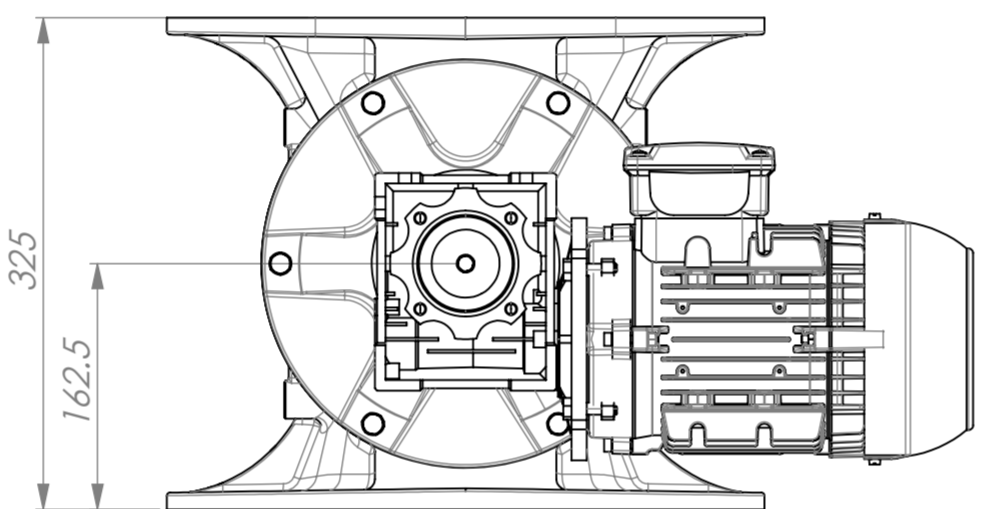
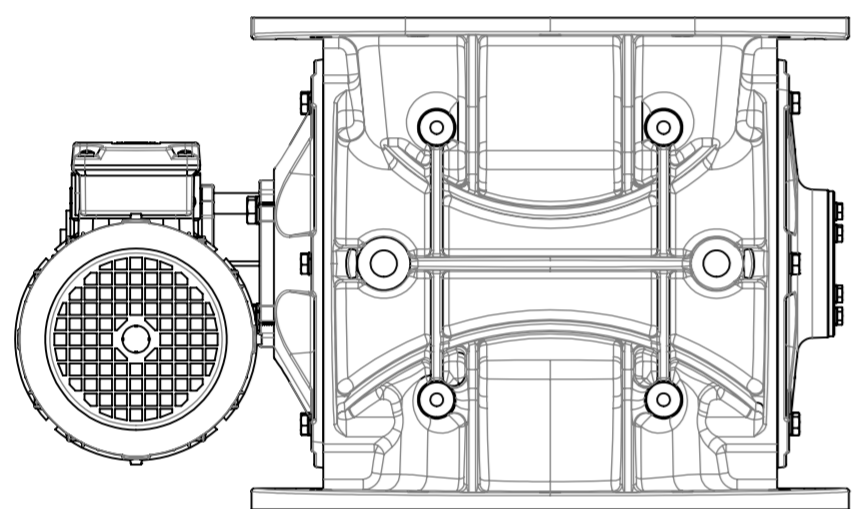

B

B

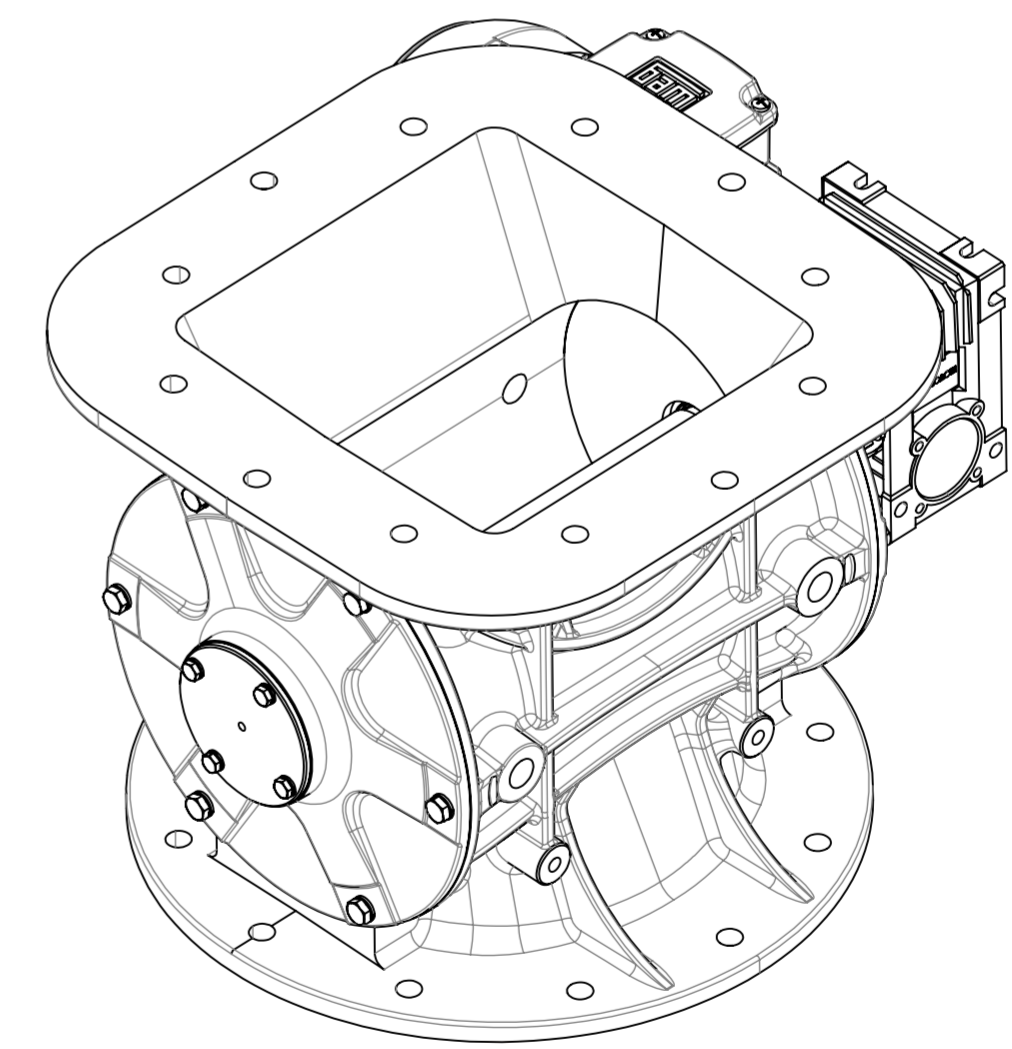
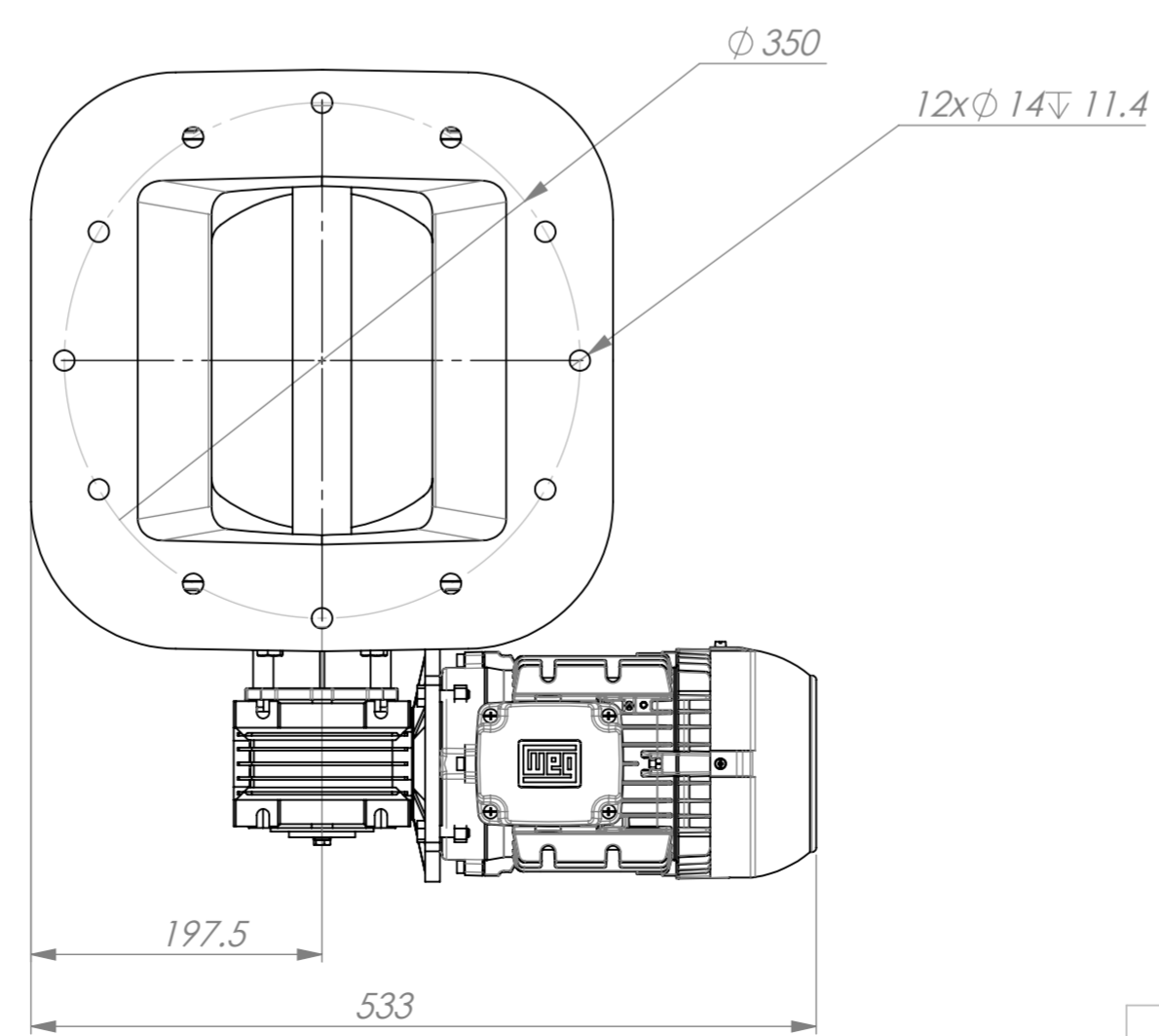

A

A

8 7 6 5 4 3 2 1

DASH NO.	NEXT ASSY.	USED ON APPLICATION

UNLESS OTHERWISE SPECIFIED 1. MARKING PER ISO 2842 2. BREAK ALL SHARP EDGES 0.1 X 45° OR 0.1R 3. DIMENSIONAL LIMITS APPLY AFTER PLATING	LAST DATUM LRT USED HEAT TREAT: FINISH SPEC. UNLESS OTHERWISE SPECIFIED DIMENSION ARE IN MILLIMETER	CUSTOMER: DESIGN: MET DESIGN PRE: APP: GROUP ENGR. PRE: APP: DRAWN: CHECKED: APPROVED:
--	---	--

PART NAME:	10" Simple Rotary Valve NMRV050
PART NO.	
SIZE A2	REFERENCE: Rev. 0
SCALE: 1:5	FILE CODE: SHEET 1 OF 3

APPLICABLE DOCUMENTS ABBREVIATIONS PER ISO-STD	GENERAL STANDARD AS PER MACHINING ISO 2768-1 mK LASER CUTTING ISO 2768-1 cK PLASMA CUTTING ISO 2768-1 vk GEOMETRICAL TOLERANCE ISO 2768-2 CASTING ISO 8852-C111 SURFACE ROUGHNESS ISO 1302 FERROUS MATERIALS AS PER ISO 4885 GALVANIZED COATING ISO 1461 Corrosion Protection ISO 8501-1:2004	HEAT TREATMENT FERROUS MATERIALS AS PER ISO 4885
---	--	---

8

7

6

5

4

3

2

1

D

D

C

C

B

B

A

A

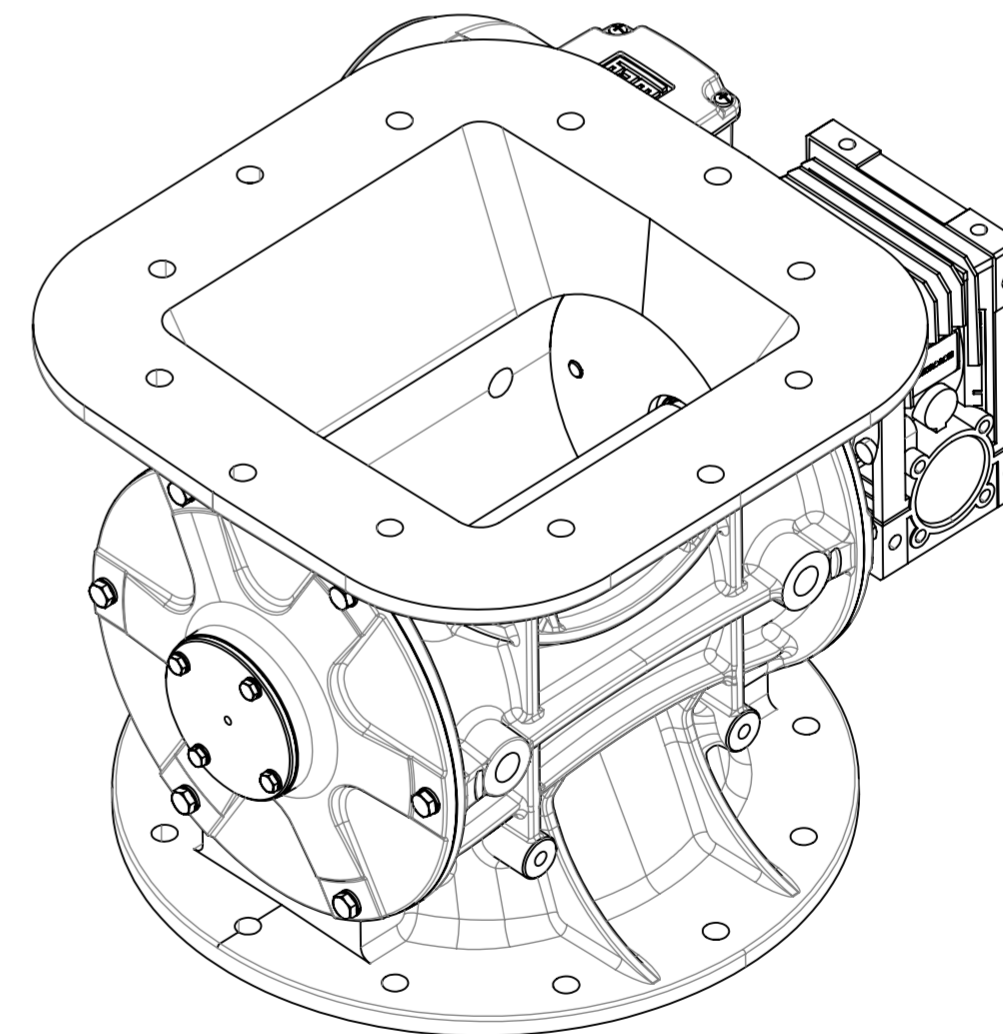
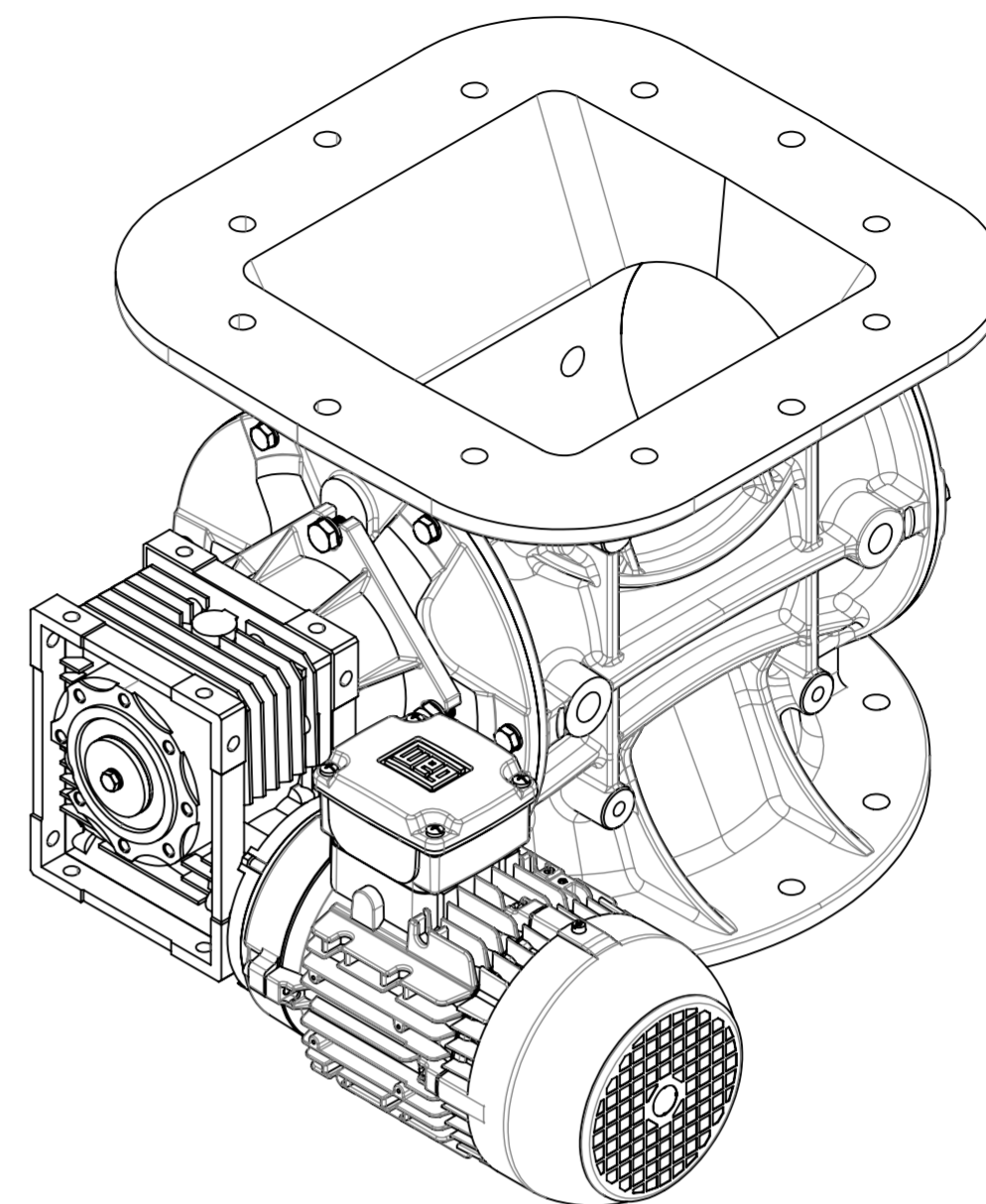
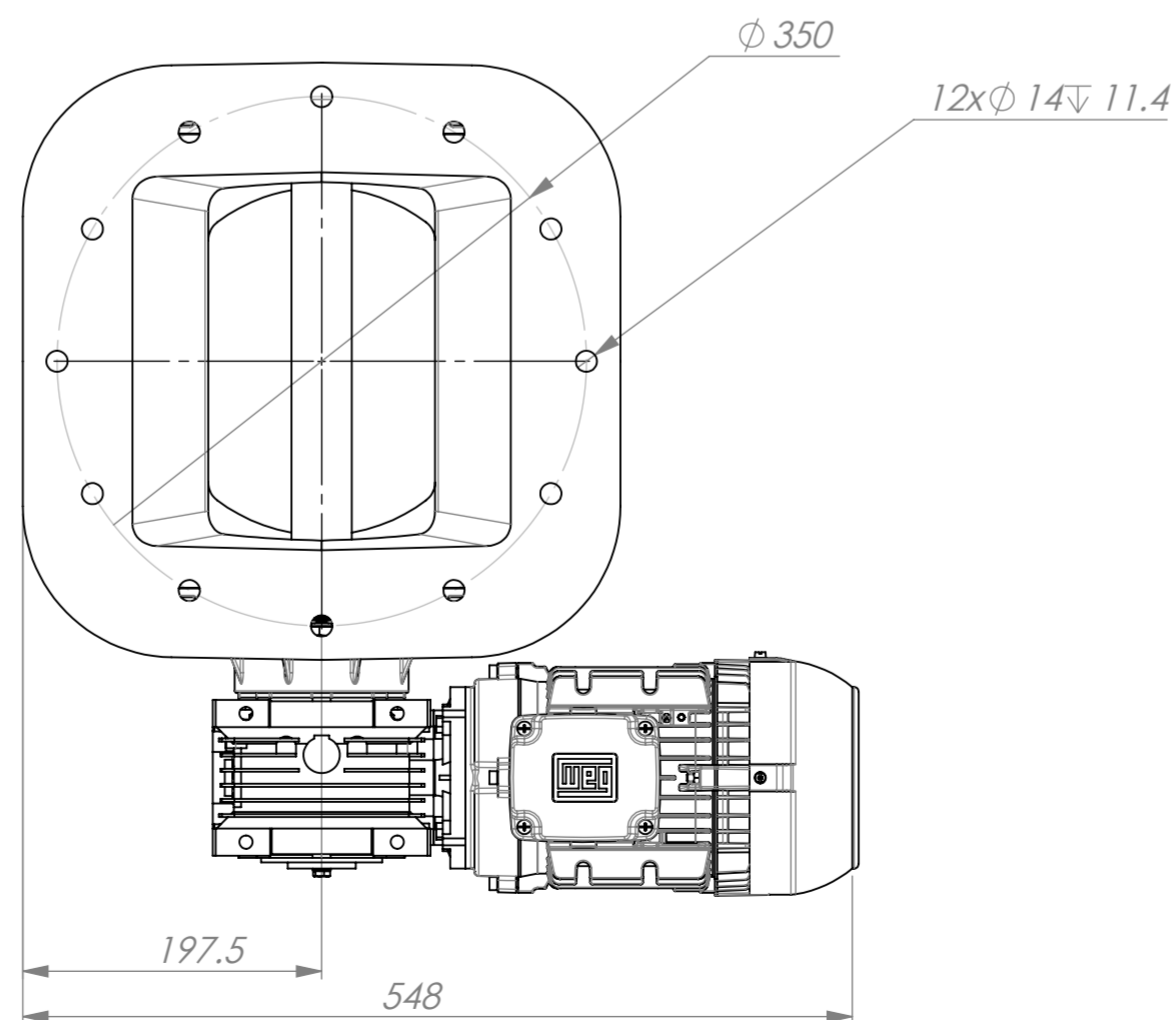
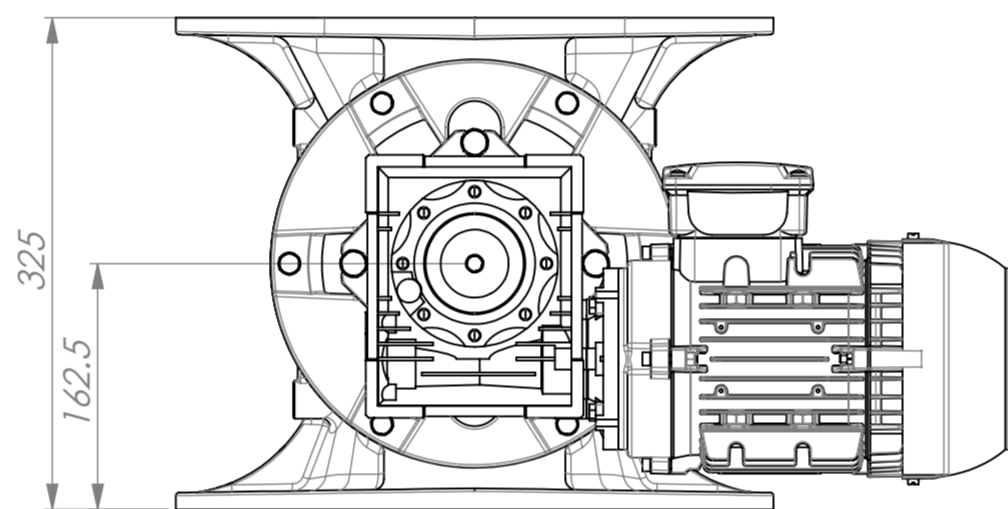
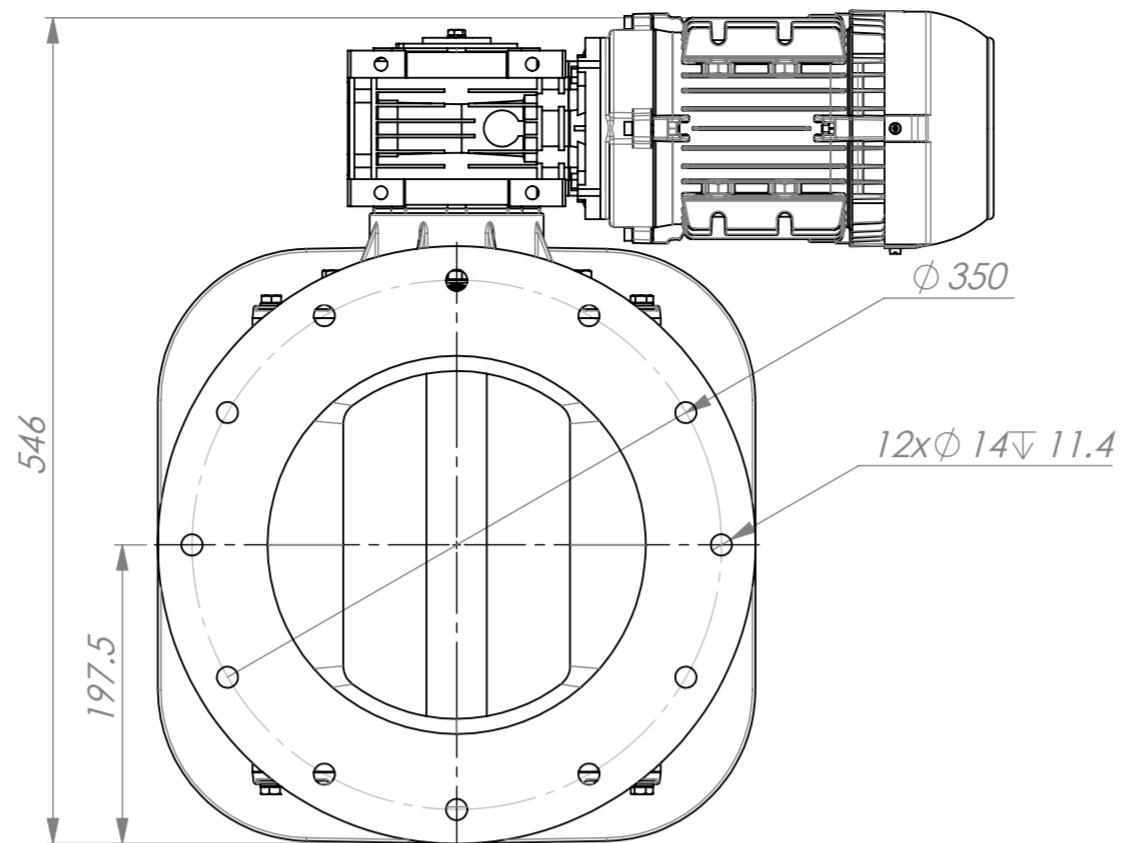
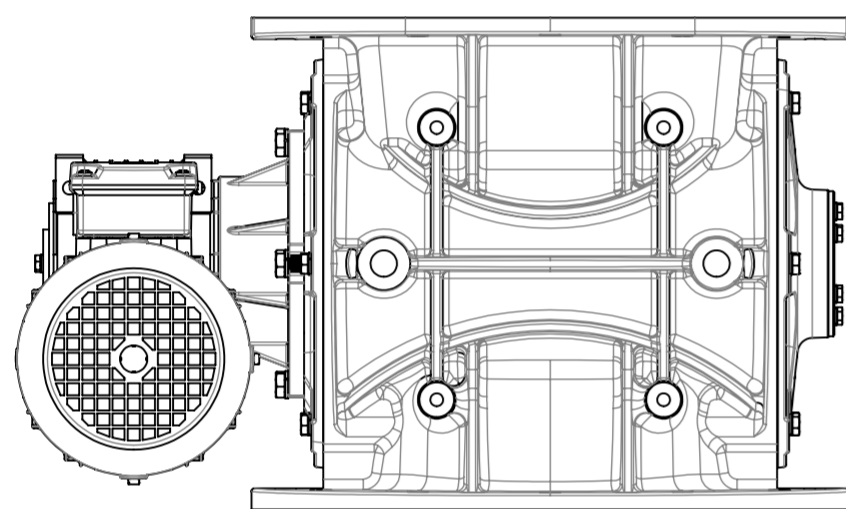

UNLESS OTHERWISE SPECIFIED		LAST DATUM LRT USED		CUSTOMER:		 PART NAME: 10" Simple Rotary Valve NMRV063	
1. MARKING PER ISO 2842		HEAT TREAT:		DESIGN:			
2. BREAK ALL SHARP EDGES 0.1 X 45° OR 0.1R		FINISH SPEC.		MET DESIGN:		PART NO.	
3. DIMENSIONAL LIMITS APPLY AFTER PLATING		UNLESS OTHERWISE SPECIFIED DIMENSION ARE IN MILLIMETER		APP:		SIZE A2	
APPLICABLE DOCUMENTS		GENERAL STANDARD AS PER		GROUP:		REFERENCE:	
ABBREVIATIONS PER ISO-STD		MACHINING ISO 2768-1 mK		ENGR. APP:		FILE CODE:	
HEAT TREATMENT		LASER CUTTING ISO 2768-1 cK		DRAWN:		Rev. 0	
FERROUS MATERIALS AS PER ISO 4885		PLASMA CUTTING ISO 2768-1 vk		CHECKED:		SHEET 2 OF 3	
		GEOMETRICAL TOLERANCE ISO 2768-2		APPROVED:			
		CASTING ISO 8052-C111					
		SURFACE ROUGHNESS ISO 1302					
		GALVANIZED COATING ISO 1461					
		Corrosion Protection ISO 8501-1:2004					

DASH NO.	NEXT ASSY.	USED ON APPLICATION

8

7

6

5

4

3

2

1

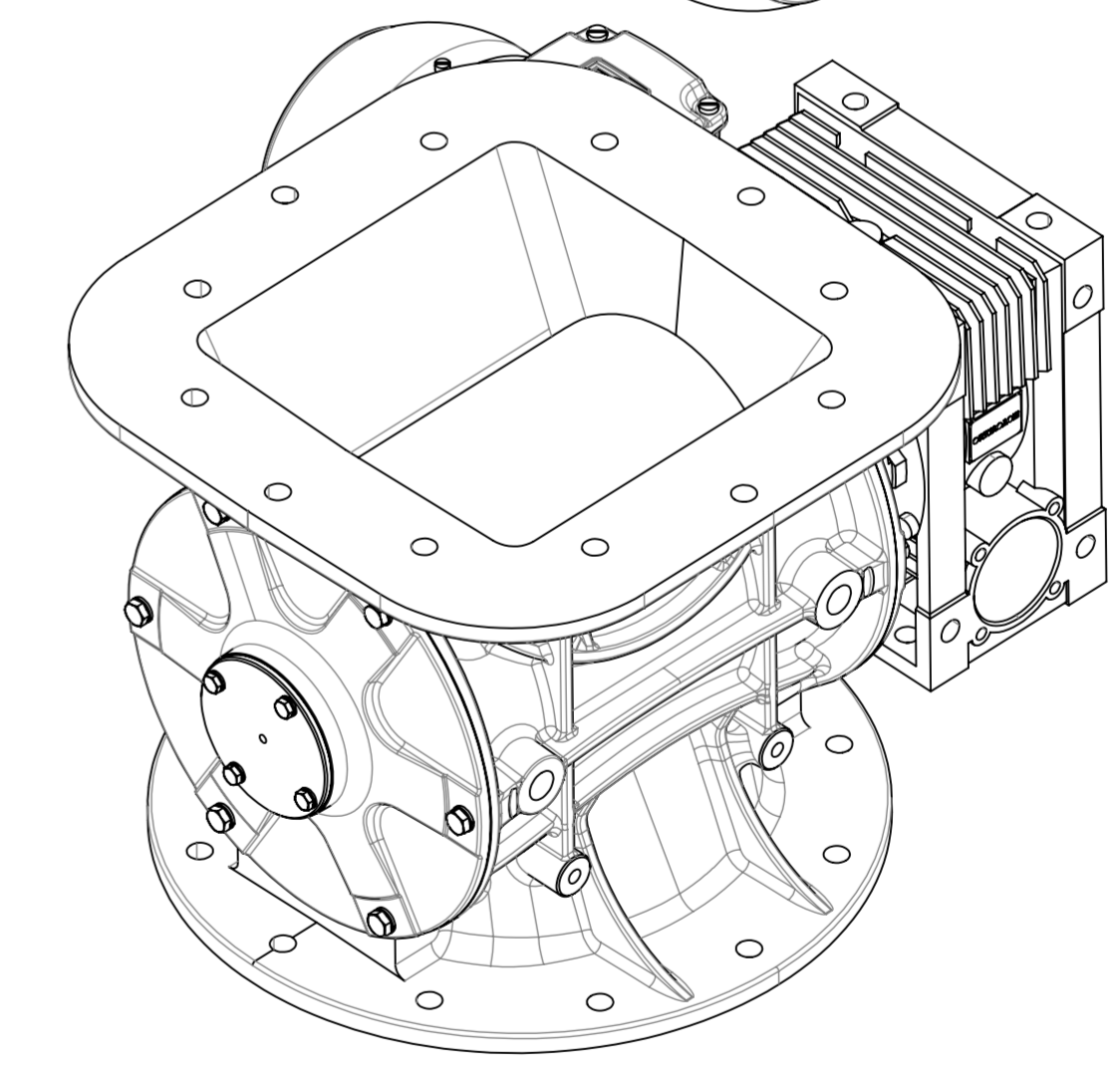
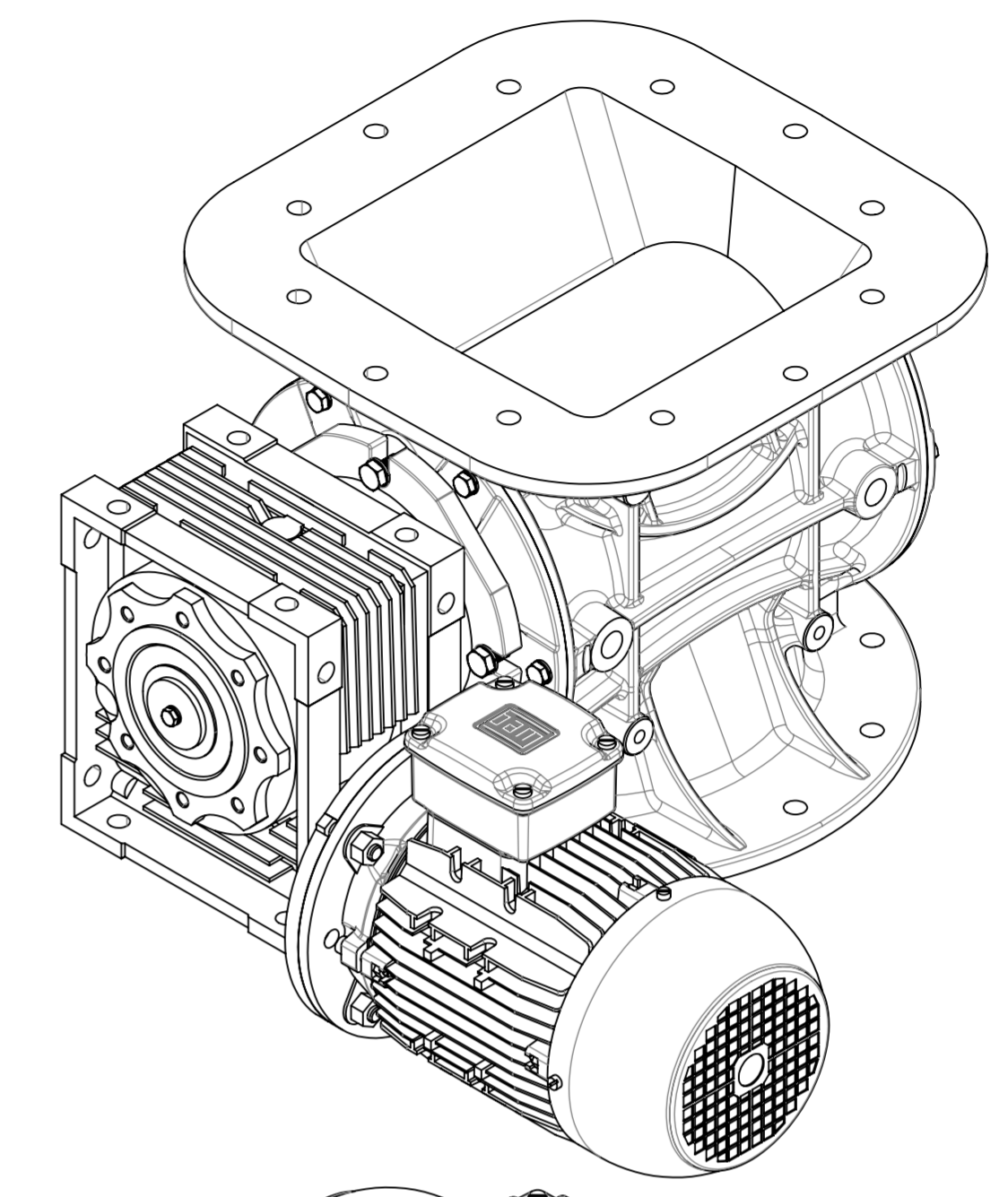
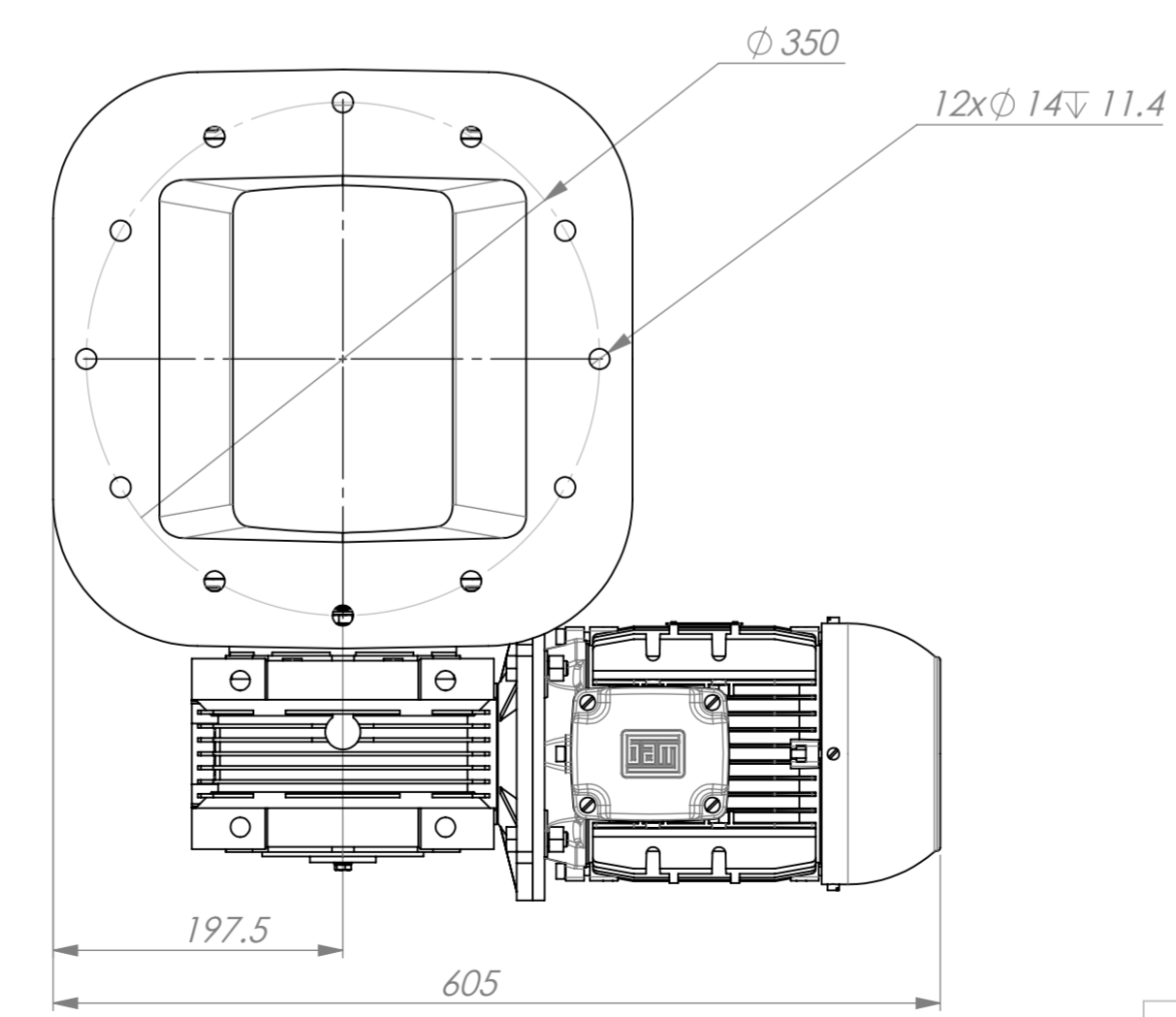
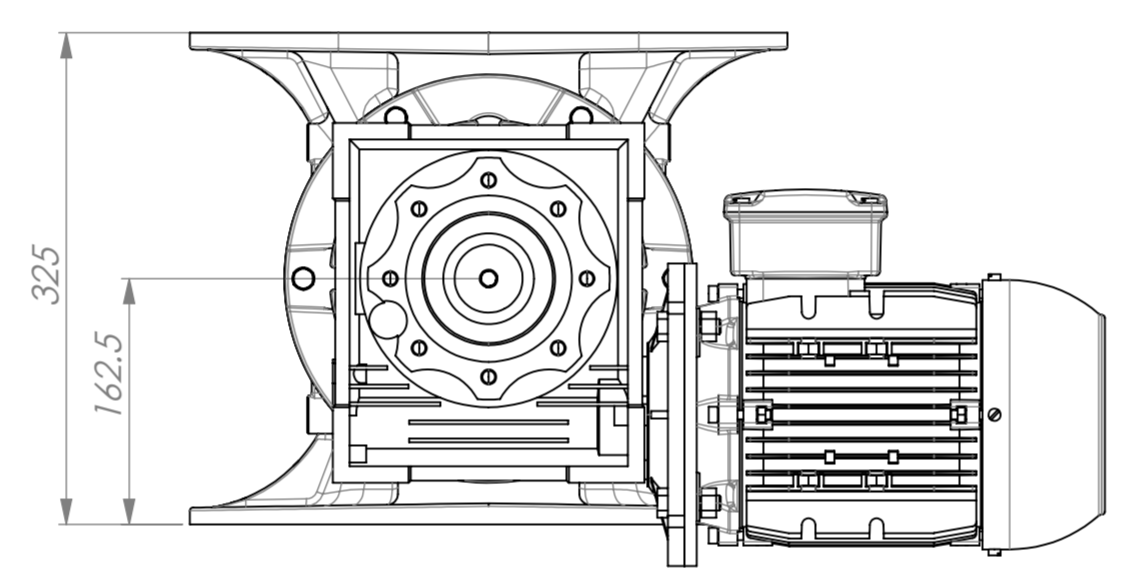
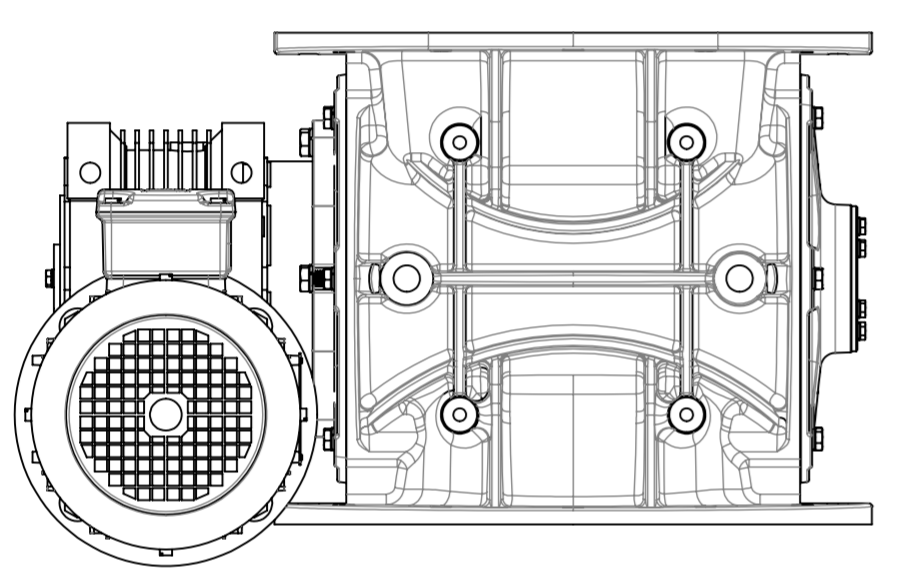
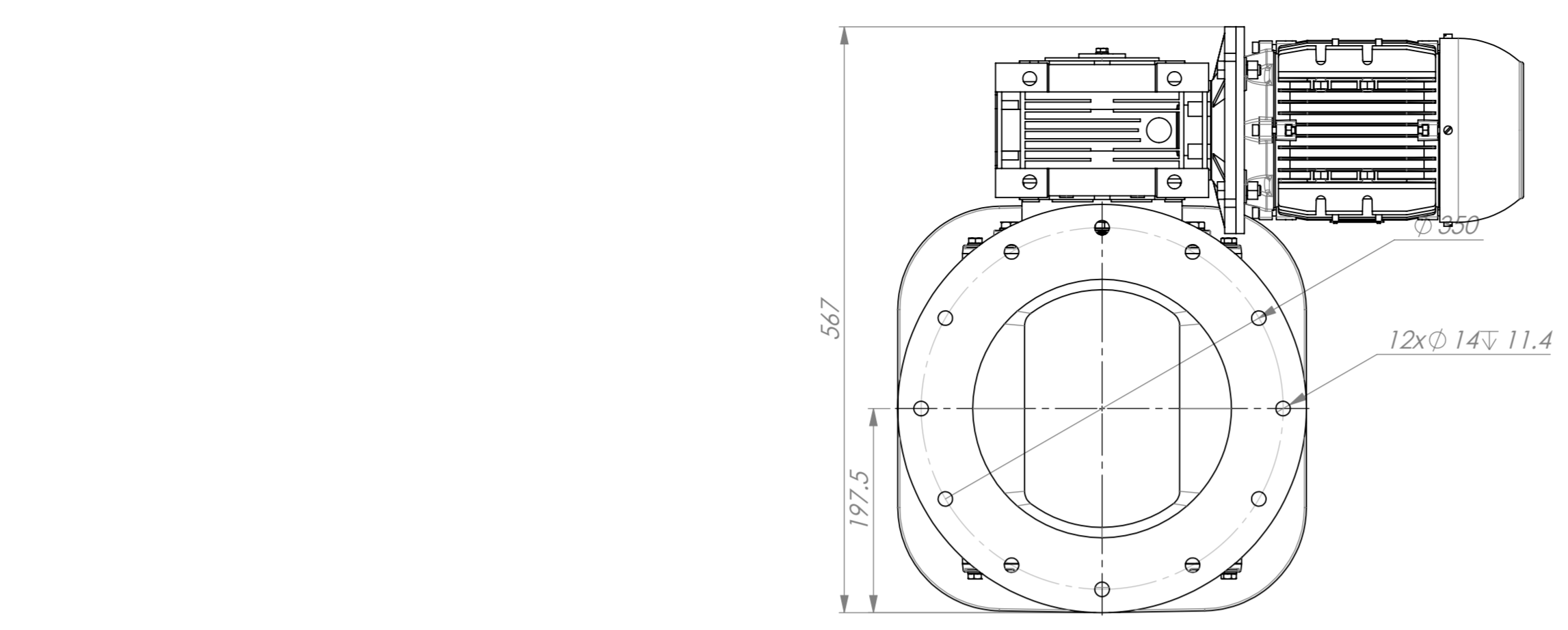

UNLESS OTHERWISE SPECIFIED 1. MARKING PER ISO 2842 2. BREAK ALL SHARP EDGES 0.1 X 45° OR 0.1R 3. DIMENSIONAL LIMITS APPLY AFTER PLATING		LAST DATUM LRT USED		CUSTOMER:		 PART NAME: 10" Simple Rotary Valve NMRV090 PART NO.
APPLICABLE DOCUMENTS ABBREVIATIONS PER ISO-STD		HEAT TREAT: FINISH SPEC. UNLESS OTHERWISE SPECIFIED DIMENSION ARE IN MILLIMETER		DESIGN: MET DESIGN PRE: APP: APP: APP:		
DASH NO.	NEXT ASSY.	USED ON APPLICATION	HEAT TREATMENT FERROUS MATERIALS AS PER ISO 4885	MACHINING ISO 2768-1 mK LASER CUTTING ISO 2768-1 cK PLASMA CUTTING ISO 2768-1 vK GEOMETRICAL TOLERANCE ISO 2768-2 CASTING ISO 8852-C111 SURFACE ROUGHNESS ISO 1302 GALVANIZED COATING ISO 1461 Corrosion Protection ISO 8501-1:2944	GROUP ENGR. APP: APP: DRAWN: CHECKED: APPROVED:	SCALE: 1:5 FILE CODE: SHEET 3 OF 3