

8

7

6

5

4

3

2

1

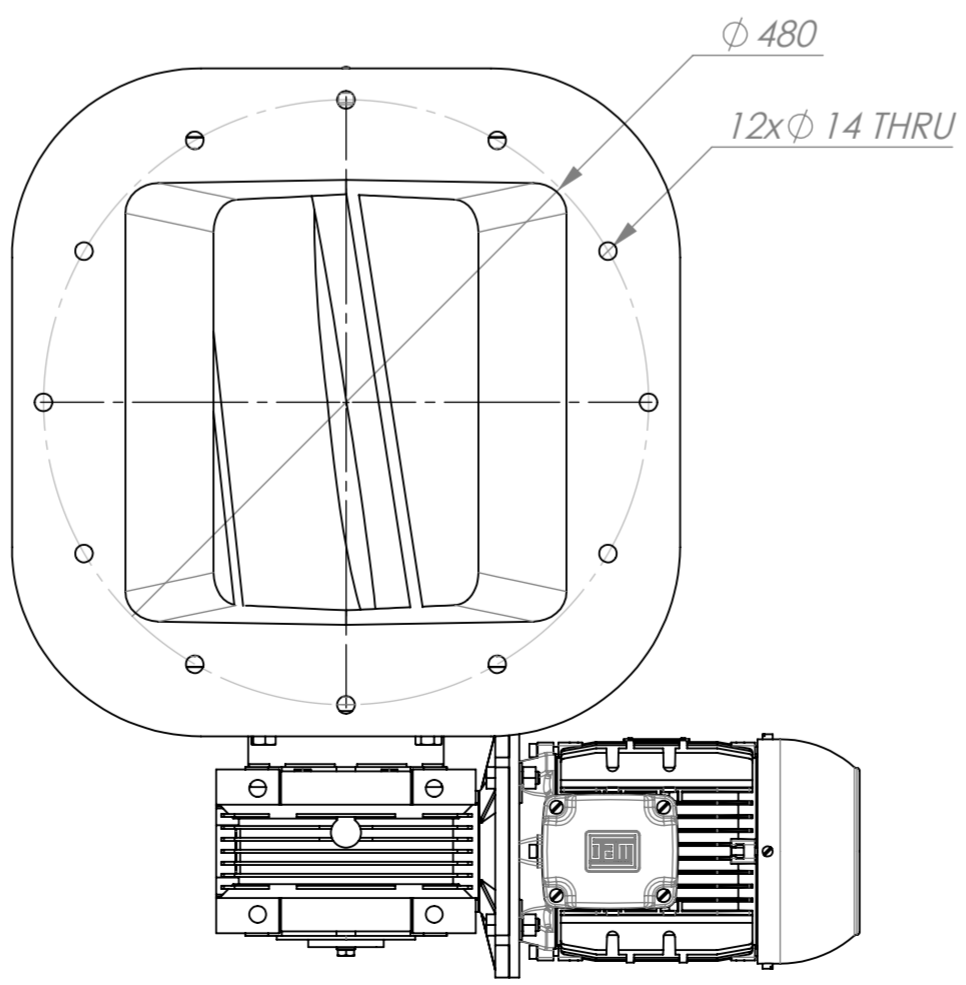
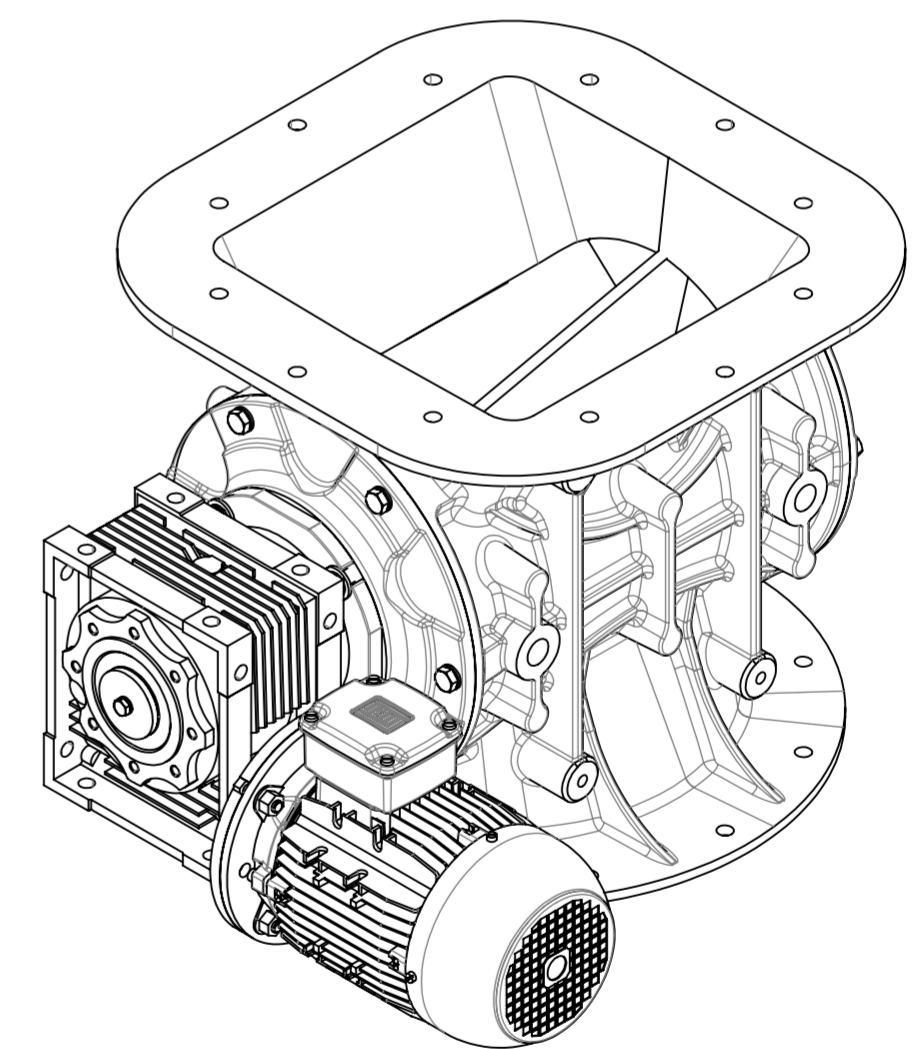
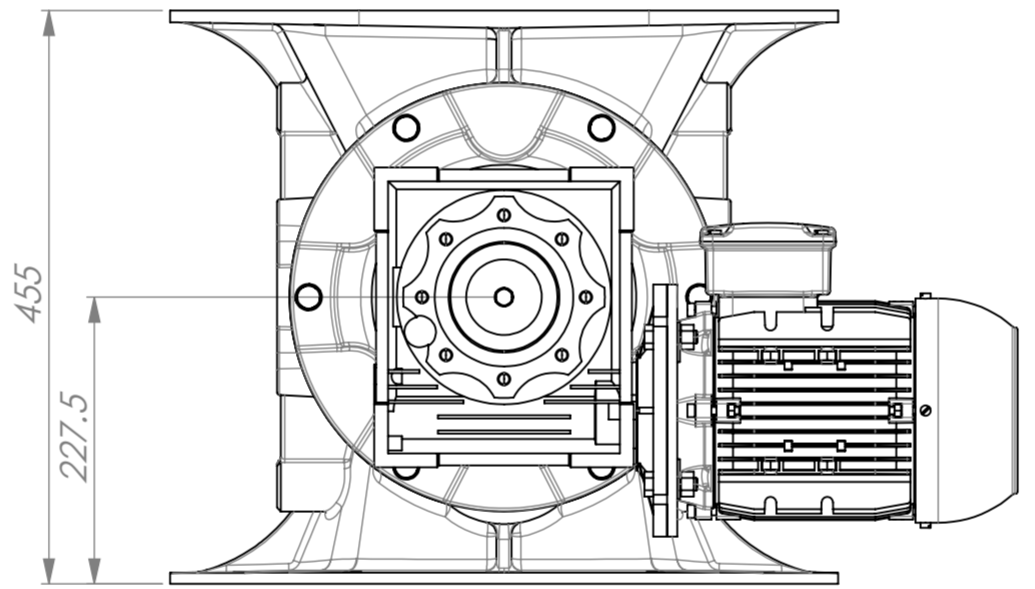
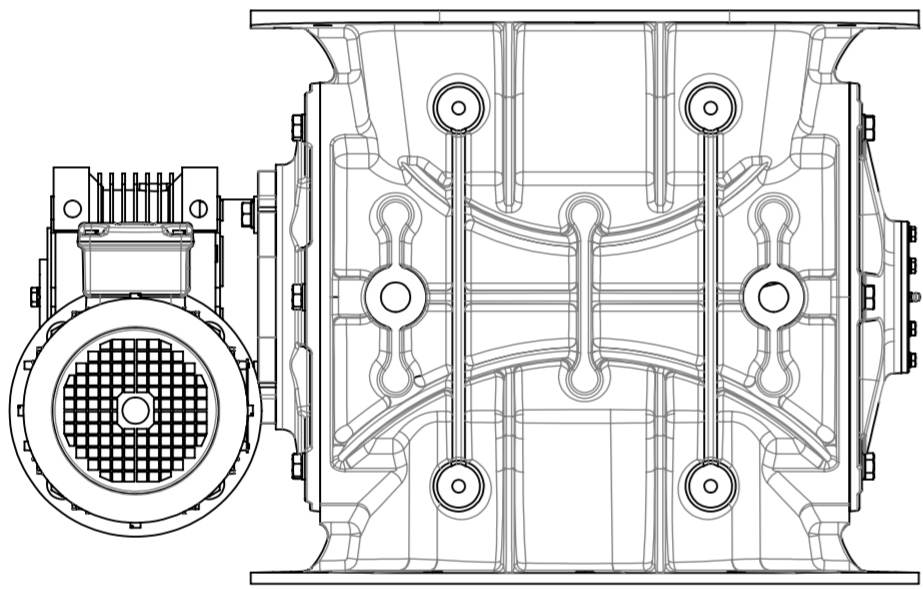
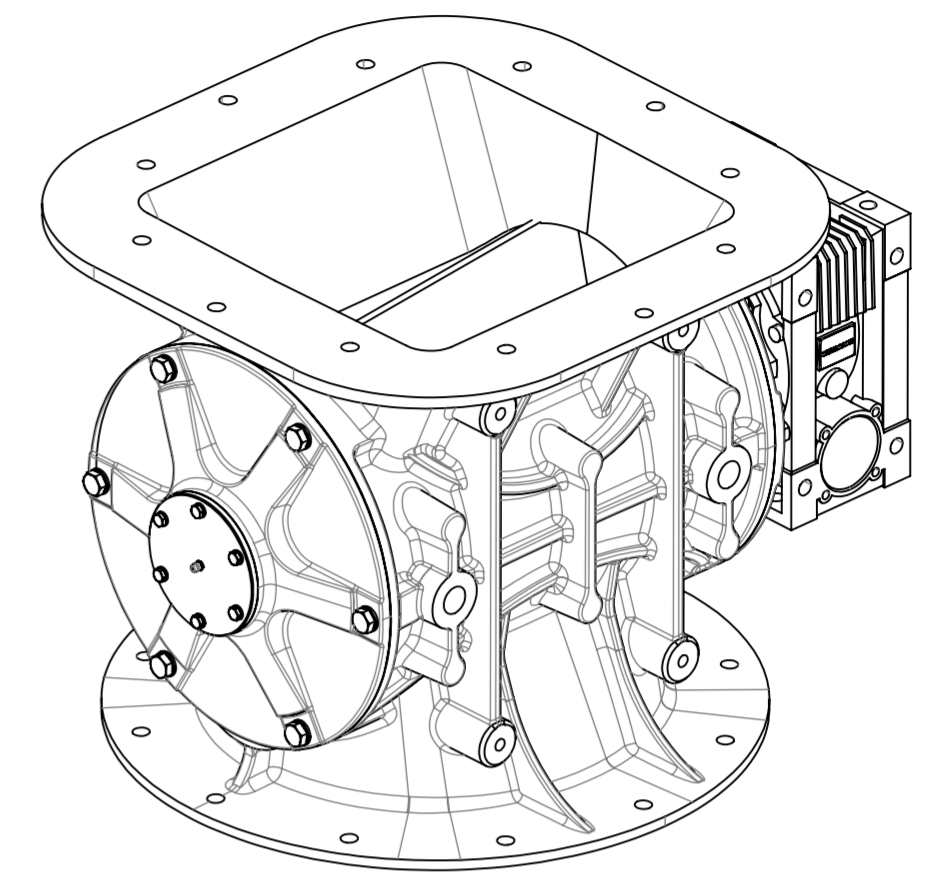
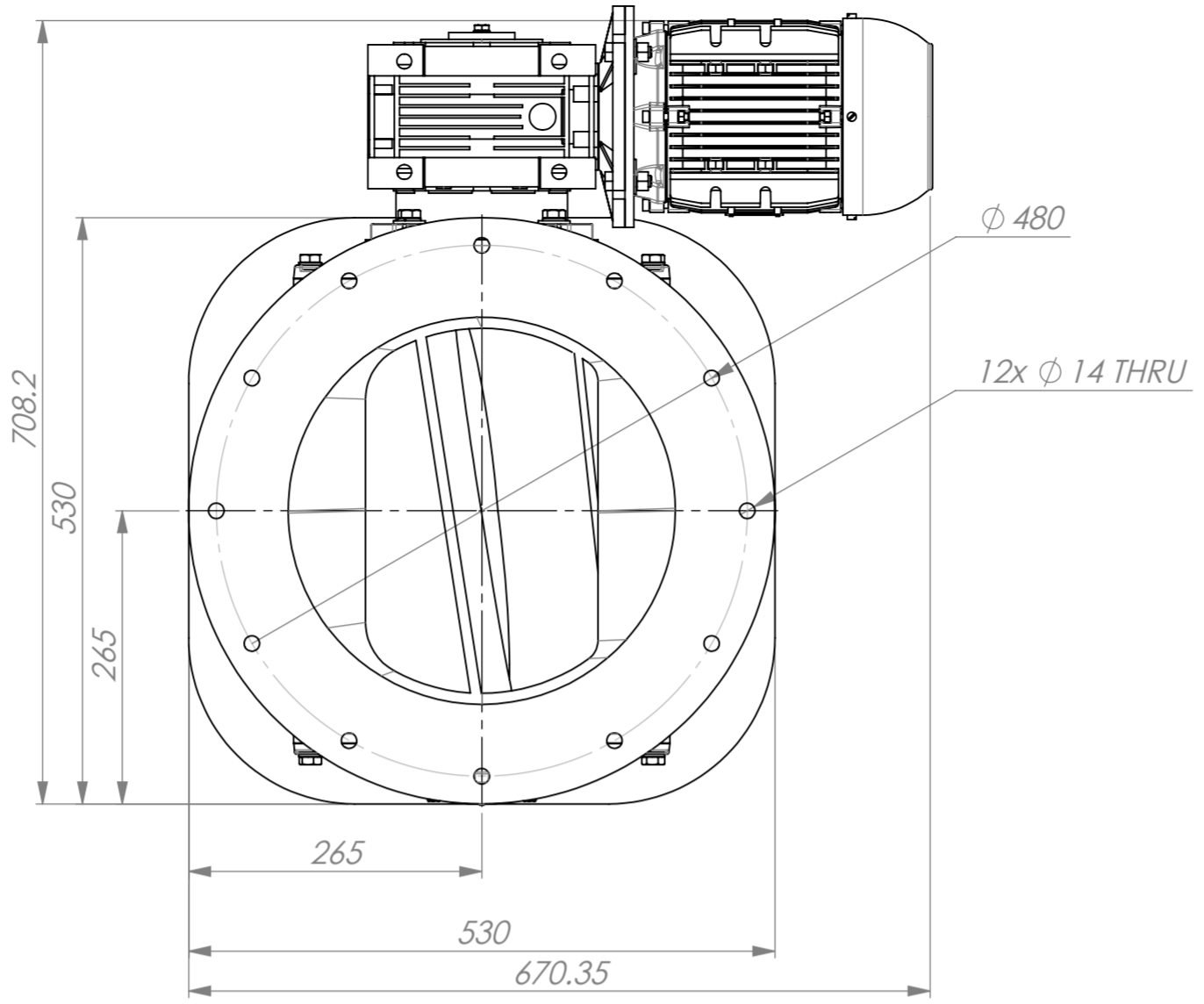

D

D

C

C

B

B

A

A

8

7

6

5

4

3

2

1

DASH NO.	NEXT ASSY.	USED ON APPLICATION

UNLESS OTHERWISE SPECIFIED
 1. MARKING PER ISO 2842
 2. BREAK ALL SHARP EDGES 0.1 X 45° OR 0.1R
 3. DIMENSIONAL LIMITS APPLY AFTER PLATING

HEAT TREAT:
 FINISH SPEC.
 UNLESS OTHERWISE SPECIFIED DIMENSION ARE IN MILLIMETER

CUSTOMER:
 DESIGN:
 MET PRE:
 DESIGN APP:
 GROUP PRE:
 ENGR. APP:
 DRAWN:
 CHECKED:
 APPROVED:

ESGM
 PART NAME:
 PART NO.
 SIZE A2
 REFERENCE:
 SCALE:1:6
 FILE CODE:
 SHEET 1 OF 1

APPLICABLE DOCUMENTS
 ABBREVIATIONS PER ISO-STD

GENERAL STANDARD AS PER
 MACHINING ISO 2768-1 mK
 LASER CUTTING ISO 2768-1 cK
 PLASMA CUTTING ISO 2768-1 vK
 GEOMETRICAL TOLERANCE ISO 2768-2
 CASTING ISO 8862-C111
 SURFACE ROUGHNESS ISO 1302
 FERROUS MATERIALS AS PER ISO 4885
 GALVANIZED COATING ISO 1461
 Corrosion Protection ISO 8501-1:2004